

MK-F SERIES

Safe, Compact and Efficient Hot Melt Applicators

Valco Melton's new MK-F Series is a specially insulated hot melt applicator, specifically designed to guarantee easy and safe handling while maintaining a compact and efficient design. Its simple, modular configuration provides optimal flexibility and easily adapts to customer needs.

- These high speed, premium style applicators are ideally suited for cartoning, labeling and graphic industries.
- Reduce power and electrical consumption with the MK-F's insulated version.
- Produce a clean application with outstanding cut-off.

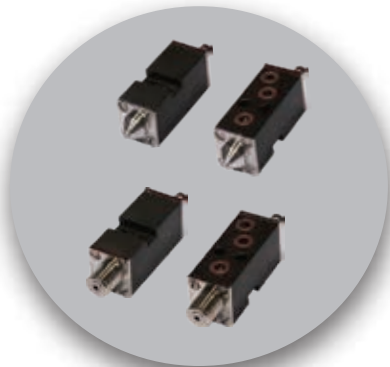

Modules

AOAC bead mini modules ensure a perfect pattern on high speed cycle applications. Zero cavity mini modules guarantee a sharp cut-off, preventing adhesive stringing.

Insulated cover

Guarantees safe applicator handling and reduces energy consumption.

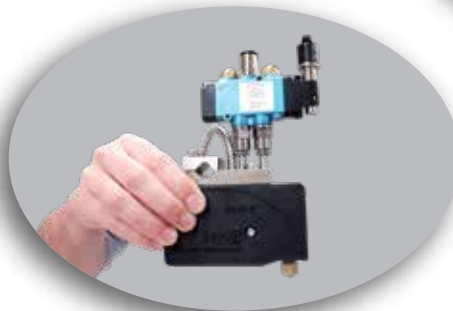

Filter

Integrated filter retains contaminants and maintains adhesive quality.





The MK-F Gun Series offers two module options: *bead* or *zero cavity*. *Bead* mini modules work with standard straight, 90° and spherical nozzles. *Zero cavity* mini modules provide extremely fast and accurate pattern placement with any adhesive type.

Valco Melton's MK-F compact dispensing guns are ideal for packaging applications with restricted space. Its flexible, simple and universal modular design allows for easy configuration to cover various application needs and is supplied with 100% compatible connection and equipment parts.

Technical Specifications

MK-F Series Characteristics	
Maximum Hydraulic Pressure	100 bar
Maximum Temperature	230° C / 446° F
Temperature Sensor	Ni 120
Pneumatic Pressure	4 -6 bar
Opening System	AOAC
Maximum Cycle Rate	4,000 cycles/min
Integrated Filter	Compatible

Applicator's Body Width	
With Insulation	32,5 mm
Without Insulation	19 mm

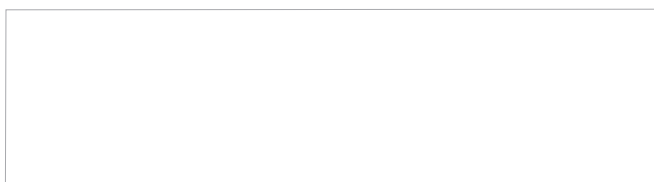

For more information, visit valcomelton.com or contact your local Valco Melton representative.

World Headquarters: USA, Cincinnati, Ohio (Corporate Offices) • Tel:+1.513.874.6550 • Fax: +1.513.874.3612

Europe Headquarters: Spain, Navarra • Tel:+34.948.321.580 • Fax:+34.948.326.584

Asia Headquarters: China, Xiamen, Fujian • Tel:+86.592.591.7854 • Fax:+86.592.591.7834

inquiry@valcomelton.com • Serving over 76 Countries Worldwide • valcomelton.com

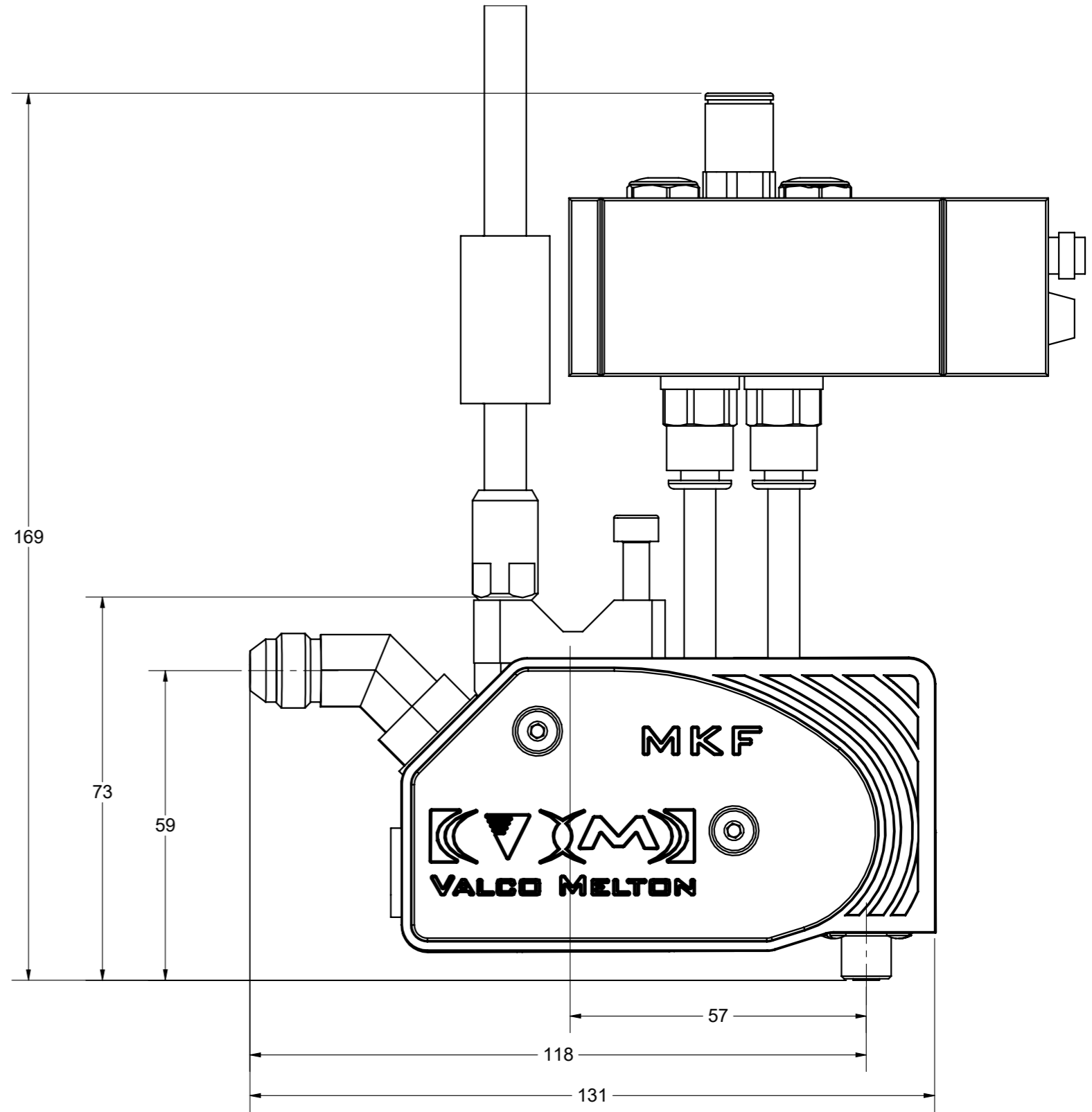
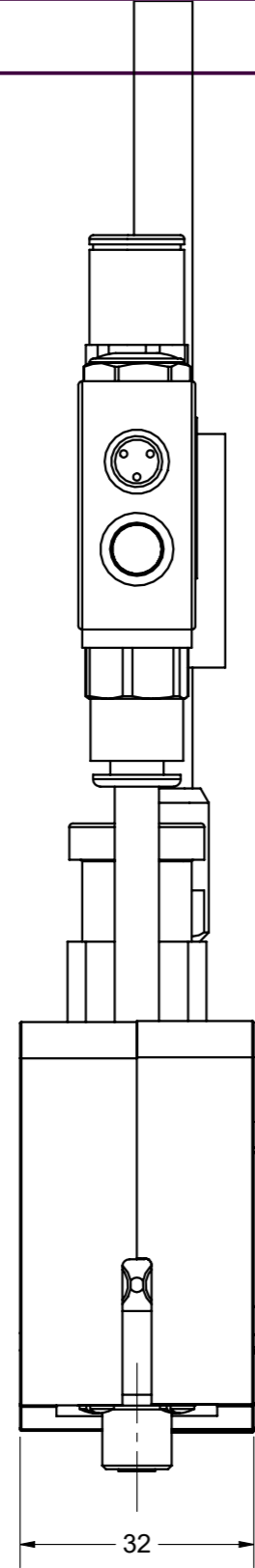
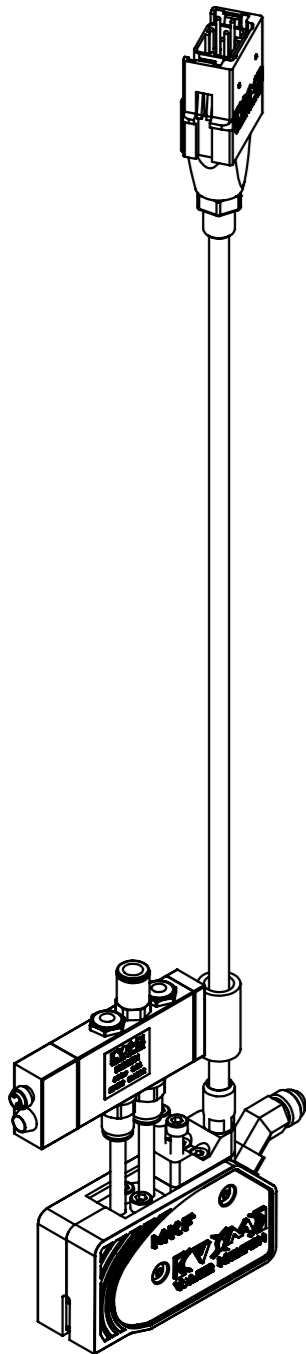

USED ON:	THREAD LENGTH DIMENSIONS ARE FULL THREAD HOLES TO BE CHAMFERED ONE UNLESS OTHERWISE SPECIFIED.	VALCO MELTON	PROPERTY CONTAINING PROPRIETARY INFORMATION WHICH MUST NOT BE REPRODUCED OR DISCLOSED WITHOUT WRITTEN PERMISSION AND MUST BE RETURNED UPON DEMAND.		
MTL:		TOLERANCES-EXCEPT AS NOTED	TITLE	Conjunto Pistola MKF1 con Carcasa	
FINISH:		ALL DIMENSIONS IN MILLIMETERS	DATE		
REV:	BREAK ALL SHARP EDGES & CORNERS (DEBURR) UNLESS OTHERWISE SPECIFIED (0,4 mm MAX)	MACHINED SURFACES N8	10/05/19	968XX533	A3
△ B	Cambio S/PM19697 10/03/2020 VGM	DRAWN BY VGM	SCALE		
△ C	PM19855 18/08/2020 GMN	CHECKED JCC	1:1		
△ D	PM21289 03/11/2022 JCC	APPROVED JCC	SHEET 1 OF 1	SUPERSEDES	
△ E	PM21496 07/09/2023 JCC				
		GENERAL TOLERANCES ACCORDING TO DIN 7168 MEDIUM			