

472A Spray Valve

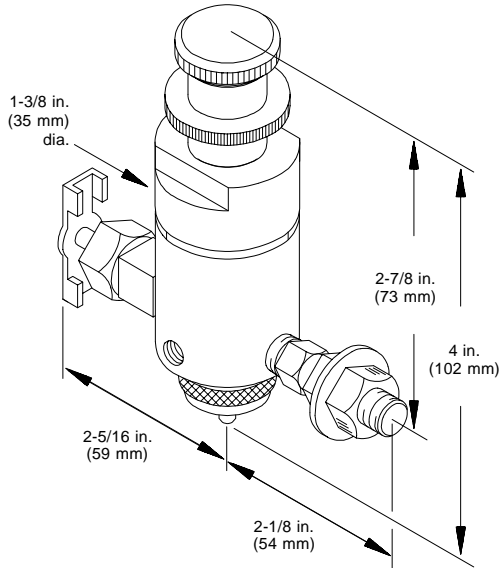

The **Model 472A Spray Valve** is an air-open/spring-closed spray valve available in brass or stainless steel. The valve features metering adjustment of output volume and a choice of air-cap style (round or fan cap) or no atomizing for bead and dot patterns.

Typical patterns produced range from 1/2 in. (13 mm) wide with the round cap (round patterns) to 3 in. (76 mm) wide with the fan cap (oval patterns). The actual pattern width is determined by the distance between the valve and the product. Maximum application distance is 3–5 in. (76–127 mm).

The 472 valve can be operated by a single 3-way solenoid air valve, or the atomizing air can be controlled by a separate 3-way solenoid air valve. The valve can be mounted to a fixed bracket or used as part of a handheld assembly.

Applications

Screen printing, palletizing, case sealing, ink and water marking

472A Handheld Assembly

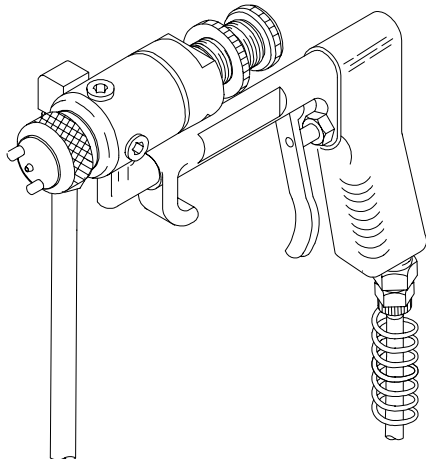

Technical Data

Height	4 in. (102 mm)
Width (with fittings)	4-7/16 in. (113 mm)
Valve operation	Air opened/spring closed
Operating solenoid valve	3-way valve
Adhesive pressure	20–30 psi (1.4–2.4 bar)
Air requirements	40–60 psi (2.75–4.1 bar)
Max. spray distance	3–5 in. (76–127 mm)

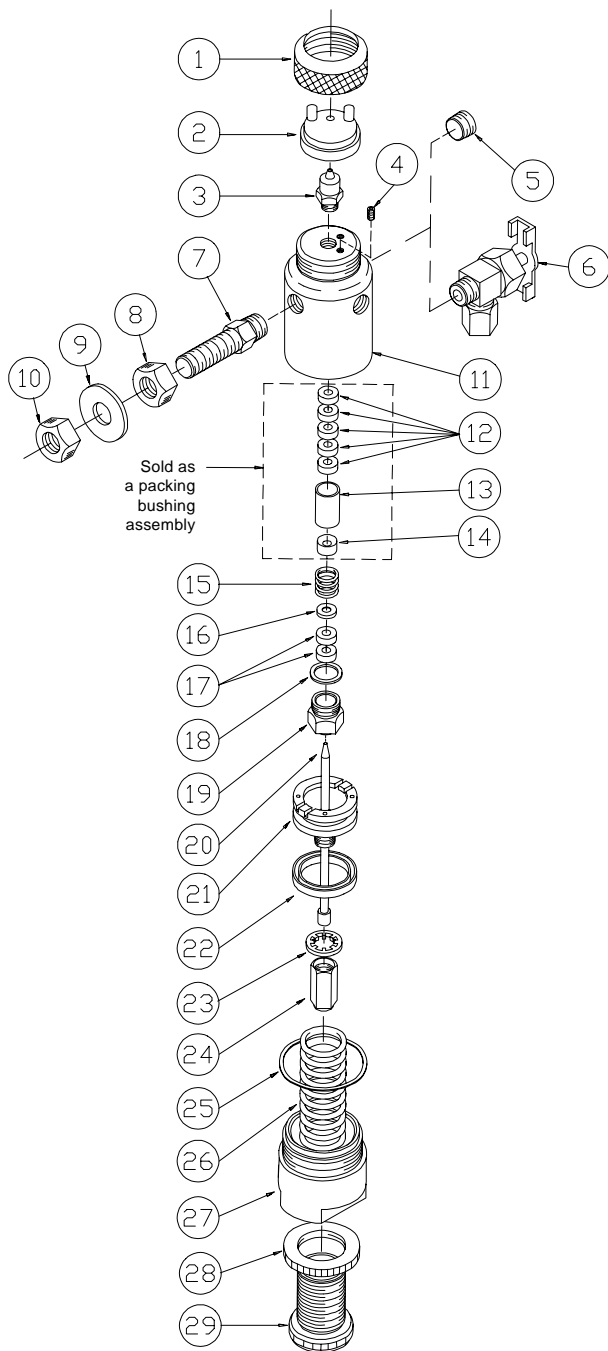

Order numbers

Model 472A Brass Spray Valves

472A brass spray valve, fan air cap	702XX537
472AT brass spray valve, fan air cap, Teflon packings	702XX535
472AR brass spray valve, round air cap	702XX500
472ART brass spray valve, round air cap, Teflon packings	702XX507
472ADT brass spray valve with spotter nozzle	702XX540
472 brass spray valve, round, stainless-steel air cap w/ Teflon packings ..	702XX509

Model 472A Stainless-Steel Spray Valves

472A stainless-steel spray valve, fan air cap, polyurethane	702XX545
472AR stainless-steel spray valve, round air cap, polyurethane	702XX512
472ADT stainless-steel spray valve with spotter nozzle	702XX548

Hand-operated Assemblies

G45-472A, brass with fan air cap	724XX032
G45-472A with air/glue tubing kit, 10 ft (3 m)	724XX033
G45-472A with air/glue tubing kit, 20 ft (6 m)	724XX037
G45-472A with air/glue tubing kit, 25 ft (7.6 m)	724XX051

Replacement parts

1 Retainer, brass valve	702XX501
Retainer, stainless-steel valve	702XX601
2 Air cap, round	702XX503
Air cap, fan	702XX538
3 Fluid nozzle	702XX504
4 Bypass air plug socket-set screw	798XX833
5 Socket-head pipe plug, brass valve	797XX041
Socket-head pipe plug, stainless-steel valve	799XX039
6 Air shut-off valve	702XX224
7 Mounting stud, brass valve	580XX015
Mounting stud, stainless-steel valve	580XX639
8 Hex nut, brass valve	798XX692
Hex nut, stainless-steel valve	798XX724
9 Flat washer, stainless-steel valve only	798XX764
10 Flange nut, brass valve	798XX693
Hex nut, stainless-steel valve	798XX679
11 Valve body, brass	702XX505
Valve body, stainless steel	702XX600
12 Leather packing (7 required)	702XX211
13 Packing gland sleeve, brass valve	702XX231
Packing gland sleeve, stainless-steel valve	702XX603
14 Packing gland, bottom, brass valve	702XX242
Packing gland, bottom, stainless-steel valve	702XX605
15 Packing spring	702XX209
16 Packing gland, top, brass valve	702XX210
Packing gland, top, stainless-steel valve	702XX604
17 Leather packing (see item 12)	702XX211
18 Packing lock washer	702XX225
19 Packing nut, brass valve	702XX212
Packing nut, stainless-steel valve	702XX606
20 Needle	702XX514
21 Piston body	702XX213
22 Piston ring seal	702XX215
23 Piston nut washer	702XX217
24 Piston nut	702XX218
25 Cap gasket	702XX220
26 Valve spring	702XX219
27 End cap, brass valve	702XX521
End cap, stainless-steel valve	702XX607
28 Locking ring, brass valve	702XX222
Locking ring, stainless-steel valve	702XX608
29 Metering adjustment screw, brass valve	702XX523
Metering adjustment screw, stainless-steel valve	702XX602

Accessories

Valve seal kit, brass valves with leather packings	702XX542
Valve seal kit, brass valves with Teflon packings	702XX543
Valve seal kit, stainless-steel valve with leather packings	702XX549
Packing bushing assembly, brass with leather packings	702XX208
Packing bushing assembly, brass with Teflon packings	702XX230
Packing bushing assembly, stainless steel with leather packings	702XX245
Packing bushing assembly, stainless steel with Teflon packings	702XX547
Adhesive for screen printing pallets, 55-gallon drum	794XX803
Adhesive for screen printing pallets, 5-gallon pail	794XX731
Adhesive for screen printing pallets, 1-gallon bucket	794XX730

Design specifications subject to change without notice.

DS019

472A Spray Valve Data Sheet

June 1994

Valco Cincinnati Incorporated

411 Circle Freeway Drive
Cincinnati, Ohio 45246, USA
TEL: (1) 513-874-6550
FAX: (1) 513-874-3612

Valco Cincinnati Limited

Hortonwood 32
Telford, TF1 4EU, United Kingdom
TEL: (44) 1952-677911
FAX: (44) 1952-677945

Valco Cincinnati GmbH

Storkower Str. 6
15749 Gallun, Germany
TEL: (49) 33764 870-0
FAX: (49) 33764 870-70