



**VALCO MELTON**

Adhesive Dispensing & Quality Inspection Systems

---

**TOTAL SOLUTIONS PROVIDER OF  
GLUING & INSPECTION SYSTEMS  
TO THE CORRUGATED INDUSTRY**

# CONTROLS

## MCP-4J

- 4-Valves, 4-Scanners
- Compatible with all glue station types except 6NC
- Jam Preventer (4 Channel)
- Auto-configuring voltage 90-240VAC
- Internal/External Pressure Control
- Job Storage (100)
- Inch/Metric
- LED display plus push-button overlay
- Auto-Glue mode
- OEM Communication
- Pulse-Purge
- Stitched patterns - jog on restart
- Data sharing with BoxChek 7
- USB port for system backups and software updates.
- Batch Count



## MCP-12/OT-12

- 4-Channel gluing and inspection
- Compatible with contact glue stations
- 4-Channels Jam
- 115VAC or 230VAC
- 6" remote-mount color touch-screen
- Internal Pressure Control
- Inch/Metric
- Easily recognized icon-based access to gluing inspection
- USB port for software updates.
- Alarm/Relay outputs
- OEM Communication (RS-232 only)
- Auto-Glue Mode



## VCX/OT-120



- Up to 16 channels in modules of 4 in any combination of sensors and valves.
- Compatible with all glue station types
- Jam Preventer (up to 16 channels)
- Auto-configuring voltage 90-240VAC
- Internal Pressure Control (up to 4)
- External Pressure Control (up to 4)
- Easily recognized icon-based access to gluing inspection
- Job Storage (1000)
- Inch/Metric
- 12" Remote-mount Color touch-screen
- Data sharing with BoxChek 7
- OEM Communication
- Auto-Glue mode
- Pulse-Purge
- Stitched patterns - jog on restart
- The VCX base can fire up 16 valve per unit and 2 VCX base units can be connected to a OT-120

## MCP-8/MCP-8I

- 8-Valves, 8 Scanners or 4-Valves, 4 Scanners, 3 Sensors
- Compatible with all glue station types.
- Jam Preventer (4 or 8 Channel)
- Auto-configuring voltage 90-240VAC
- Internal/External Pressure Control
- Job storage (100)
- Inch/Metric
- 4.5" Color touch-screen
- Alarm/Relay outputs
- Remote mount screen option
- Backup/Restore to/from external media
- Data sharing with BoxChek 7
- OEM Communication
- Auto-Glue mode
- Pulse-Purge
- Stitched patterns - jog on restart



**In addition to the above features, the MCP-8I includes:**

- 4-Valves, 3-Inspection Sensors, 1 marking valve
- Inspection capabilities (includes CGS-40 & CGS-40S)
- Scanner Lockout
- Supports kick, spray and linear ejector with tracking, no rotary ejection



# CONTACT GLUE STATIONS

BOARDRUNNER™

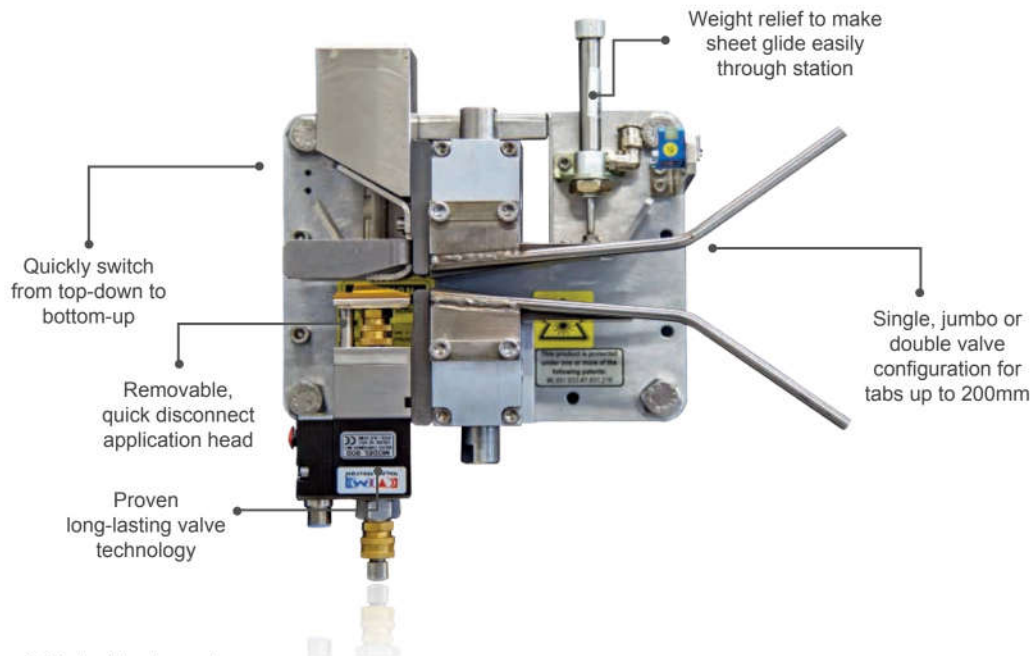

- 900 electric glue valve
- Quick change from bottom-up to top-down
- Adjustable gap
- Adjustable weight relief air pressure
- Accepts applicator heads for glue patterns up to 2.5" wide (64mm) or in jumbo format up to 6" wide (150mm)
- Patented floating head design offers proper contact without impeding product flow
- Available as jumbo & dual-valve jumbo
- Integrated photo-eye

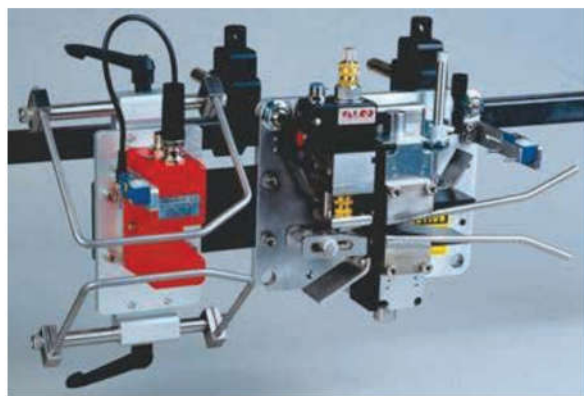
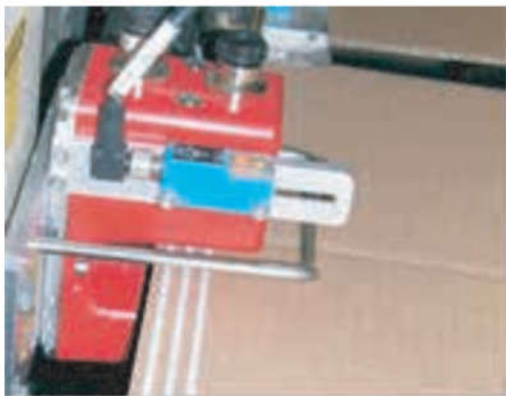

- BoardRunner glue station shown with CGS-40 Glue inspection sensor.
- Cost effective quality assurance option available with FlexosealPRO series controls.
- CGS-40 is also available as a stand-alone unit for glue pots with FlexosealPRO series and MCP-8i controls.

## V-75/VO-700

---

- 366 pneumatic glue valve (24V or 12V)
- Adjustable spring pressure
- Accepts applicator heads for glue patterns up to 1.75" wide (45mm) or 3.75" wide (95mm) in jumbo format
- Available as jumbo
- Must be rebuilt for top-down/bottom-up contact glue station



## COMBISTATION™

---

- 366 pneumatic glue valve (24V or 12V)
- Valves can be quickly replaced with quick-on modules
- Station can run bottom-up and top-down
- Adjustable spring pressure
- Available as jumbo



# NON-CONTACT GLUE STATIONS

## 3NCR™/4NCR™

- 524 electric glue valves (up to 4)
- Quick reversing with two easy-hold levers
- Low restriction nozzles
- Patented tip sealer for top-down/bottom-up
- Adjustable product guides
- Adjustable delay to park glue station
- Can run in auto-glue mode on tab side
- Supports stitch and jog modes
- Staggered starts and glue lengths to match tab angles



### COST-SAVING

Fast and simple order setup/change over



### ADHESIVE FLEXIBILITY

Top-down or bottom up / high-pressure or low-pressure



### LESS WASTE

Precision glue patterns with minimal adhesive consumption.



### VERSATILITY

Flexibility with contact or non-contact systems



### 3NC™/4NC™

---

- Can run in auto-glue mode
- Supports stitch and jog modes
- Tip sealer technology for valves
- Low restriction nozzles
- 524 electric glue valves (up to 4)
- Supports 3 beads on 1/4" centers about 3/4 wide pattern or 19mm wide pattern
- Staggered glue lengths and pattern starts to match tab angles
- Adjustable product guides

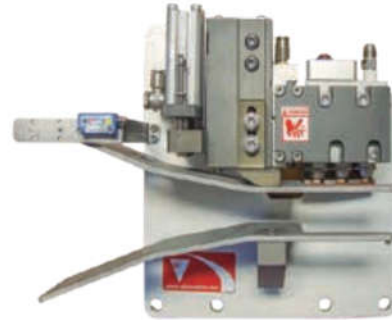

### 6NC™/8NC™

---

- Adjustable product guides
- Can run in auto-glue mode
- Supports stitch and jog modes
- Supports angled glue patterns to match tab angles
- Tip sealer technology for valves
- Low restriction nozzles
- 524 electric glue valves (up to 8)
- Supports 6 valves on 11.4mm centers about 2.5" wide pattern or 64mm
- Staggered glue lengths and pattern starts to match tab angles



### BOARDRUNNER™ NC

---

- 900 electric glue valve
- Adjustable gap
- Adjustable weight relief air pressure
- Accepts up to 4-hole angled non-contact nozzles



# PUMPING SYSTEMS & BALANCING REGULATORS

## 1:1, 3:1, 6:1 BALANCING REGULATOR

- Pressure balancing regulator - relieves excessive pressure that occurs during high speed stops
- Ultra-precise and fast pressure control
- No shaft seals
- Easy rebuild
- Various ratios for specific application demands
- Rolling diaphragm design for frictionless movement and no losses





## B 3 2 1 : 1 REGULATOR

- Stainless steel construction
- Air-piloted
- Easy manual adjust



## D D - 1

- Trusted reliability of a 1:1 diaphragm pump
- Electronic shifting
- High flow rate
- Suction from totes, drums, and pails
- 1/2 NPT and 1/2 BSPP inlet/outlet fittings
- 24VAC source from Valco Melton controls or optional transformer box
- Wall mount, lid mount, or drum mount



## E P P - 9

- High flow-rate 9:1 piston pump
- Electronic reversing
- Intelligent SLOW MODE feature prevents high cycle rates that occur during priming or when adhesive supply is blocked or depleted (dry cycling).
- Advanced Seal technology for 4 times the life of previous piston pumps
- 24V power supply are available
- 115/230VAC transformer
- Easy to clean and install
- In excess of 50 bar available glue pressure



## P F R M - 5

- Complete assembled package, 14:1 pump, 5:1 balancing regulator, 4-port manifold, and filter
- Shaft/seal cartridge for fast and simple repair
- Drum mount, wall mount, and pail mount options



# TAPER CONVERSION KITS

## HOT OR COLD GLUING PACKAGE

Valco Melton offers hot melt and cold glue taper conversion kits for General and Universal Tapers. These kits add flexibility and cut costs by enabling you to glue a manufacturers glue tab style box rather than tape. The components of the kits include brackets, applicator valves & heads, a pressurized glue source (melt tank with pump for hot melt systems) and solenoid-operated air valve that ties into the existing limit switch for the tapping mechanism.

- Eliminate costly tape, associated storage, and handling problems
- Increase belt speed for more production
- Improve quality with stronger bonds
- Operate with coated and non-coated board stock

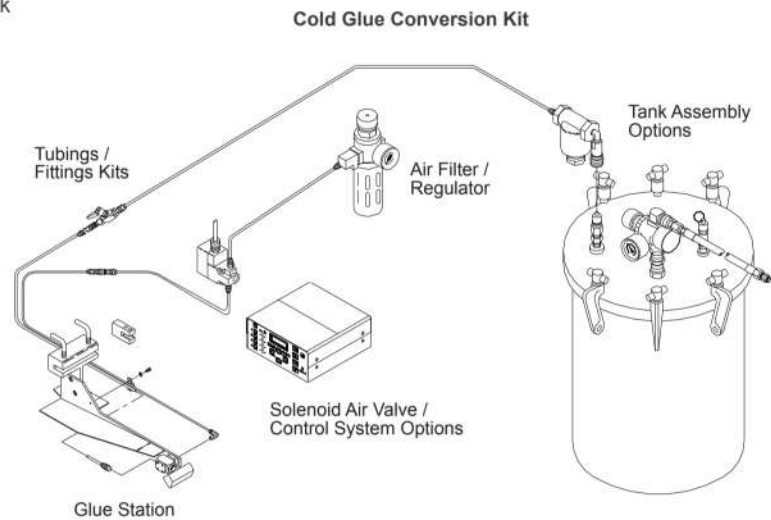

### MCP-6

The MCP-6 control is a cost-effective control that is set up to replace limit switches on taper machines. The MCP-6 can control tape, cold glue, and hot melt valves. This control can be set up as a timer or encoder base system.



### EC Series Hot Melt Unit

Valco Melton's EC Series hot melt adhesive unit is supported by the most current features and technology and offers optimum reliability and control.

- LCD operator panel for ease of use and programming
- Optional integrated auto feed system and glue pattern control.
- Common footprint allows for universal installation
- Fast-reversing piston pump system

## TAB TRIM REMOVERS



### TR500M

---

- Eliminate scrap issues such as false system starts and unglued boxes
- Total weight: (8.8 lbs) 4kg
- Electric or Pneumatic versions available



### TR500ME ELECTRIC TRIM REMOVER

---

- Eliminate tab trim and scrap
- Automatically speeds up when it detects products running on the machine.
- Mounting bracket package included
- Two high-speed, 4000 rpm motors
- Long lasting high wear-laminated blade sets
- Includes mounting hardware, lightweight aluminum extrusion

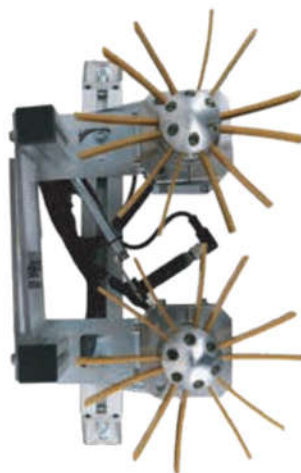

# THE HOT MELT ALTERNATIVE

## COST EFFECTIVE MELT UNITS

Valco Melton's D4, D10 and D16 Series Units are ideal for packaging, graphic/print finishing, product assembly, labeling and various paper converting applications. All D Series units feature an LED display, spur gear pump with fixed or variable speed, "key-to-line" control, and a multi-functional control system. Other options include an integrated glue pattern control, line speed pressure control and integrated auto-feed systems.

- Efficient and clean operation featuring Teflon® coated tank with demand melt heating grid
- Achieve uniform output pressure to match line speed with built-in pressure run-up control
- Reduce dynamic seals and wear-components with the all electric gear pump and motor
- Easy-to-connect HMI communication through the melter interface I/O's
- Avoid compatibility problems with Valco Melton's industry standard hoses, guns and tank filters
- Complies with major approval codes worldwide



## MXM VALVES

Valco Melton's MXM electric hot melt valve are the workhorse for most Valco Melton hot melt dispensing solutions. The MXM electric valve can operate at extremely high speeds reaching 15,000 cycles per minute for short bursts and have a lifetime capable of more than 2 billion cycles depending on operating conditions. The MXM is widely known as the EcoStitch capable valve in Food and Beverage packaging where end users see their adhesive usage reduced by up to 75% for instant ROI and process improvement.

Combine the speed of hot melt with the strength of cold glue.

- Cost-effective solution
- Maximize production
- Clean application
- Fast system payback
- Side feed or top feed assembly available for folder-gluer installation



## PUR

---

Valco Melton's IsoMelt Mini and D4 PUR Series are designed to process reactive hot melts such as PUR. Units feature a fully integrated, multi-functional controller that is accessible from a user-friendly screen, which allows for fast and easy configuration changes and provides 'key-to-line' capabilities.

- Ideal for plastic packaging
- Swiveling tank lid allows for faster changes of PUR slugs, minimizing downtime

IsoMelt Mini



D4-PUR



## DRUM & PAIL UNLOADER

---

Often, a 55 gallon (200 L) drum unloader or 5 gallon (20 L) pail unloader is preferred over a conventional tank unit.

- Unloaders are true melt-on-demand units. This keeps adhesive fresh and reduces charring that will occur in many tank units. PUR adhesives and adhesives sensitive to temperatures can be better controlled in an unloader.
- Many adhesives (particularly PSA and PUR) can be purchased more economically in drum form.
- Unloaders can generally melt and supply adhesive faster than standard tank units. 300 pounds per hour and higher can often be achieved.
- Drum unloaders are ideal for high viscosity adhesives that do not flow easily in a tank. Unloaders can commonly run in excess of 100,000 cps.



# VISION & INSPECTION SYSTEMS

## HOW IT WORKS

---

Work with your glue system and ClearVision inspection cameras with one screen using BoxChek7 inspection software. BoxChek7 brings users complete information on production line performance in real time. The screen simultaneously displays job statistics, defect images and history bar to facilitate analysis.

## BENEFITS

---

- Detect and identify defective gluing (hot melt or cold glue), folding, barcodes, print registration, corrugator scores, as well as issues with sheets such as skew.
- Minimize configuration times with the system's ability to learn the position of the cameras and sensors.
- Streamline support sessions using the online chat window.
- Intuitive interface that displays real time images and data from each of the installed systems.
- Defect and performance data for all boxes stored locally in SQL database and can be easily accessed remotely with MeasurementChek.

## SYSTEMS

---



GLUECHEK



SCORECHEK



FOLDCHEK



BUNDLECHEK



PRINTCHEK



GAPCHEK



REGCHEK



CODECHEK

# MAKING QUALITY VISIBLE

## GLUECHEK



GlueChek takes a picture of every glue pattern. The system analyzes the glue pattern to ensure that no gluing problems exist. When a gluing problem is found, GlueChek shows the defect on the screen with a large "X", notifies operators by alarm, then marks the defective box and saves an image of the gluing problem.

By identifying and removing all defects before shipment, box makers can now provide 100% perfectly glued boxes to their customers. Having saved a picture of every defect builds operator confidence, helps maintenance troubleshoot, checks for skewed boards, and increases customer satisfaction.

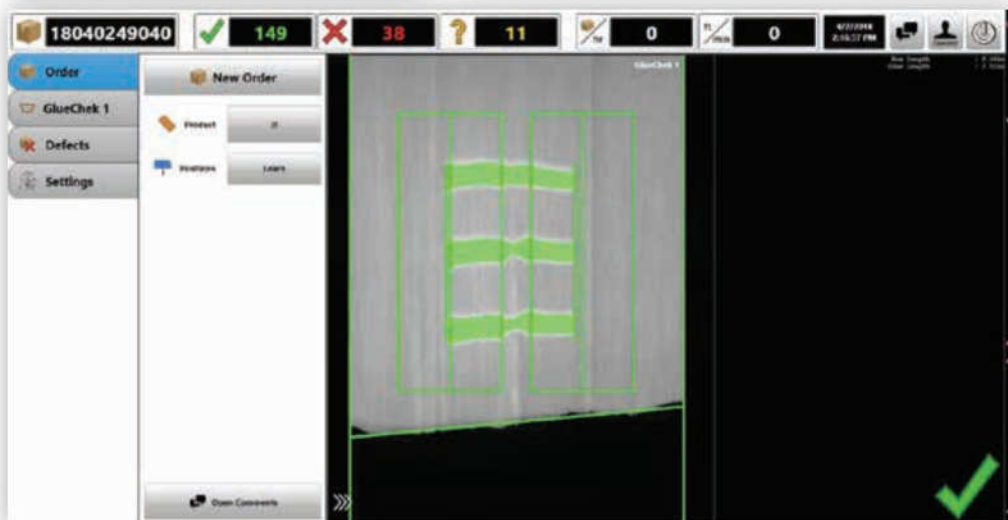

# CAMERAS

## FOLDCHek



FoldChek takes a picture of every manufacturer's gap. It analyzes the gap for width and skew. When a problem is found, FoldChek clearly displays the defect on the screen showing what is wrong, sounds an alarm, marks the defective box, and saves an image of the defect. Customers can now be assured that their boxes are free from folding problems and gap variation. Box makers can accurately specify gap requirements to meet customer needs and ensure only perfectly folded boxes arrive at the customer's door.

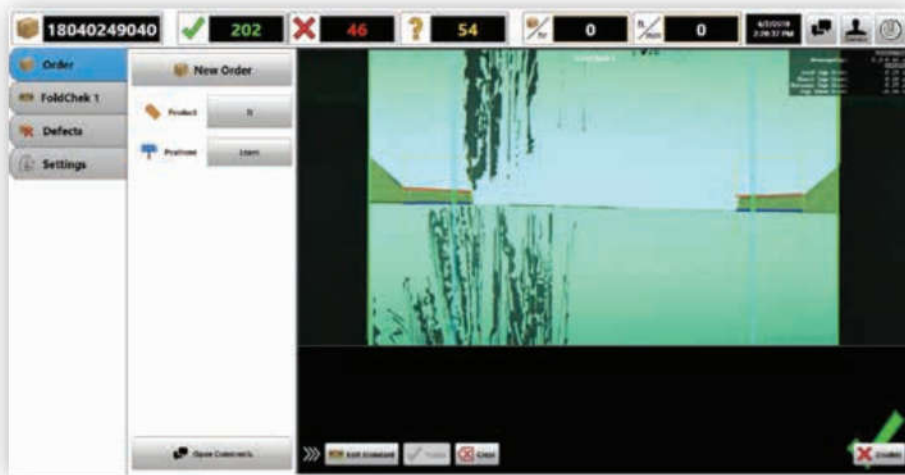

## BUNDLECHEK

When any ClearVision camera identifies a defect, BundleChek receives a signal and marks the defective bundle. Then, when the bundle containing the defective box is identified by the BundleChek camera, it is immediately diverted to an alternate conveyor.

With BundleChek, manufacturers and customers alike can be sure that defective boxes are eliminated before the shipment makes it out your door.





## CODECHEK



- Eliminate customer quality problems caused by mixed copy
- Detect most types of binary and 2D barcode formats, including UPC, Code 128, QR Code and Data Matrix
- Read barcodes at high speeds up to 30 boxes/sec, and in areas up to 23 x 23 cm
- Adapts to your production requirements with the ability to mount the camera bottom-up or top-down
- Integrate up to five different quality assurance systems using the ClearVision BoxChek 7 camera-based inspection platform

## PRINTCHEK

PrintChek is a full sheet inline print detection system used to inspect unwanted spots, registration (color-to-color and color to cut), stripes, scratches, color, missing print, smearing, double-print/ghosting, drying, barcodes, blank measurement, board damage, delta-e color density, and skew. Can be used on flexo folder-glueers and die-cut presses.

## GAPCHEK



GapChek images the front and back of the entire straightened bundle and measures the lead and trail gaps directly at the box edge. Each box is therefore measured as completed, statistics collected and marked for ejection of bundles with out-of-tolerance folds. GapChek is compatible with any conveyor type and mounted after the counter-ejector or bundle strapper to ensure easy mounting of cameras and lights.

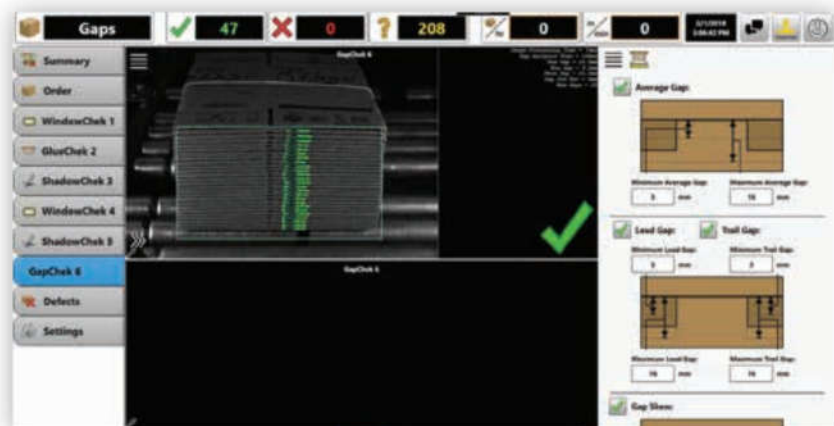

# CAMERAS

## SCORECHEK



Deliver perfectly manufactured boxes to your customers by inspecting and ensuring the integrity of corrugator scorelines on your sheets using ScoreChek. Using innovative ShadowChek camera technology, ScoreChek automatically images the sheet to highlight the scorelines for analysis. Scoreline position can then be accurately verified in order to determine the blanks are being fed correctly and the scores are within tolerances.

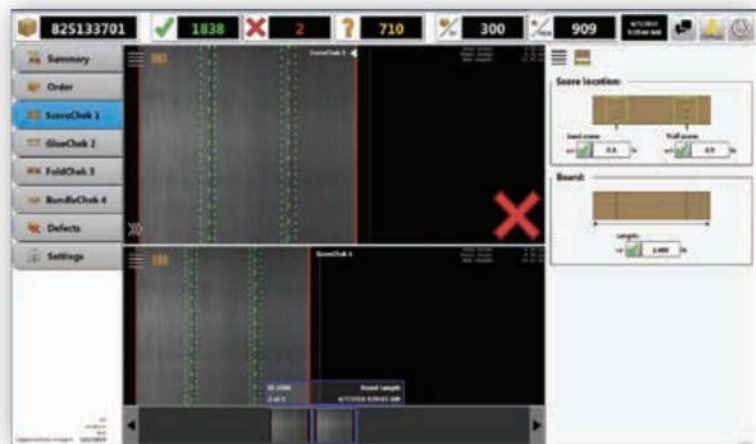

## REGCHEK



Using high speed imaging, RegChek captures images of each and every box to measure print variation in relation to the desired value set at the beginning of the order run. Where box design allows for it, RegChek also detects variations in the print registration in relation to the board edges, as well as variations in the slot depth.

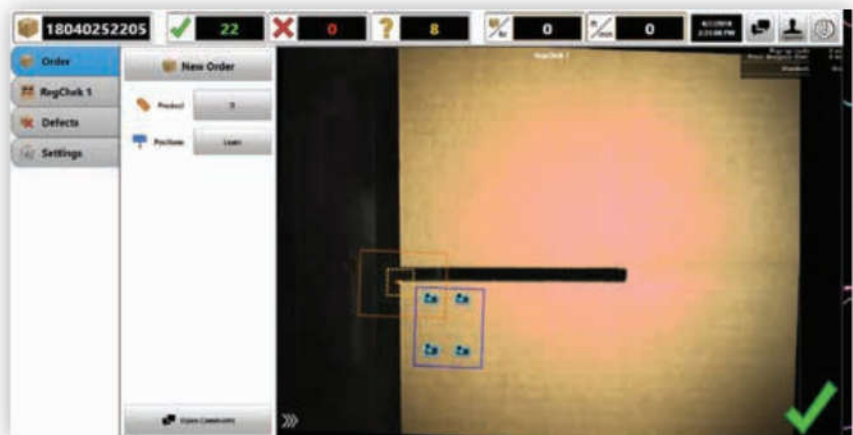

## GOT SUPPORT?

### PREVENTIVE MAINTENANCE

---

- ✓ Valco Melton's AssurancePlus is designed to keep your gluing systems performing at the highest quality, while minimizing machine downtime.
- ✓ Ensure the availability of a trained Valco Melton service technician for a recurring scheduled date and time.
- ✓ Preventative maintenance costs 3-5 times less than reactive maintenance costs.
- ✓ Scheduled semi-annual Valco Melton technician PM visits reduce the total cost of ownership by properly training personnel, replacing wearable parts and helping to identify potential problems before they become larger problems affecting productivity and quality.

### SUPPORTCHEK

---

- ✓ 24 hour remote support
- ✓ Monthly remote login and diagnostic check (with email report)
- ✓ Remote backup in case of system failure
- ✓ Access to MeasurementChek (tracks all boxes and orders run through machine)

---

**VALCO MELTON IS THERE WHEN YOU NEED THEM WITH A NETWORK SPANNING 96 LOCATIONS ACROSS THE GLOBE**

---

**FOR MORE INFORMATION, GO TO  
[VALCOMELTON.COM/SUPPORT](http://VALCOMELTON.COM/SUPPORT)**

**World Headquarters**

**USA, OH, Cincinnati** | Tel: +1.513.874.6550  
[info@valcomelton.com](mailto:info@valcomelton.com)

*North America Sales & Service Centers*

**America Manufacturing, Sales & Service Centers**

**Canada**, Vancouver, B.C.  
**ClearVision Technologies**  
 Tel: +1.604.998.4012  
[canada@valcomelton.com](mailto:canada@valcomelton.com)

**USA West Coast, CA**, Petaluma  
**GMS-Vansco**  
 Tel: +1.707.285.3392  
[inquiry@gmsvansco.com](mailto:inquiry@gmsvansco.com)

**Mexico**, México D.F.  
 Tel: +52.55.6278.1727  
[mexico@valcomelton.com](mailto:mexico@valcomelton.com)

**Colombia**, Bogotá  
 Tel: +57.313.421.0926  
[colombia@valcomelton.com](mailto:colombia@valcomelton.com)

**Brazil**, Sao Paulo  
 Tel: +55.11.99919.3510  
[brazil@valcomelton.com](mailto:brazil@valcomelton.com)

**Europe Manufacturing, Sales & Service Centers**

**Spain**, Navarra, Orcoyen | Tel: +34 948 321 580  
[spain@valcomelton.com](mailto:spain@valcomelton.com)

**France**, Valence | Tel: +33 (0) 4 75 78 13 73  
[france@valcomelton.com](mailto:france@valcomelton.com)

**Italy**, Brescia | Tel: +39 030 2732544  
[italy@valcomelton.com](mailto:italy@valcomelton.com)

**Italy**, Brescia | **ERO s.l.r** | Tel: +39 030 2731503  
[info@ero-gluers.com](mailto:info@ero-gluers.com)

**Benelux**, The Netherlands | Tel: +31 252-673673  
[benelux@valcomelton.com](mailto:benelux@valcomelton.com)

**Hungary**, Budapest | Tel: +36 1-214-4705  
[hungary@valcomelton.com](mailto:hungary@valcomelton.com)

**UK**, England, Telford | Tel: +44 1952-677911  
[uk@valcomelton.com](mailto:uk@valcomelton.com)

**Germany**, Düsseldorf | Tel: +49.211 984 798-0  
[germany@valcomelton.com](mailto:germany@valcomelton.com)

**Poland**, Siechnice | Tel: +48 71 889 04 50  
[poland@valcomelton.com](mailto:poland@valcomelton.com)



Direct Sales Centers ●  
 Distributors Worldwide ●

**South, Southeast, West & Central Asia Manufacturing, Sales & Service Centers**

**Turkey**, Istanbul | Tel: +90 212 327 99 71  
[turkey@valcomelton.com](mailto:turkey@valcomelton.com)

**India**, Bangalore | Tel: +91.80.28378111  
[india@valcomelton.com](mailto:india@valcomelton.com)

**UAE**, Sharjah | Tel: +971.521305960  
[uae@valcomelton.com](mailto:uae@valcomelton.com)

**Singapore**, Singapore | Tel: +65 850 95355  
[singapore@valcomelton.com](mailto:singapore@valcomelton.com)

**East Asia Sales & Service Centers**

**China**, Shanghai | [china@valcomelton.com](mailto:china@valcomelton.com)  
**China**, Xiamen | Tel: +86.592.591.7854  
 Fax: +86.592.591.7834 | [china@valcomelton.com](mailto:china@valcomelton.com)

To find the office nearest you, visit:  
<http://bit.ly/2Cb8Fv2>  
 or snap a picture of this QR Code



BC-004