

DD-1

Electronically Controlled Diaphragm Pump

Valco Melton's DD-1 Diaphragm Pump represents an innovative breakthrough in pump design. The electronic reversing control is extremely reliable and is not affected by normal wear characteristics of mechanical devices. The DD-1 Diaphragm Pump is automatically reversed by low-voltage, solid-state electronics. Many diaphragm pumps use air-powered mechanical devices, which reserve the pump stroke. These reversing mechanisms can "hang-up" and stall the pump when operated at low air pressure or when cycling at slow speeds. To overcome these limitations, common diaphragm pumps must be operated at air pressures high enough to ensure stroke reversal. For most applications, this results in an expensive waste of compressed air. In addition, mechanical reversing devices wear out, resulting in frequent downtime for maintenance and rebuilding.

- The electronic reversing control offers extreme reliability
- Not affected by normal wear characteristics of mechanical devices
- Teflon® diaphragms come standard
- Can be cycled very slowly or operated at very low air pressure without stalling or hanging up
- Lightweight, injection-molded nylon construction
- Modular for fast, simple in-line service
- No lubrication required

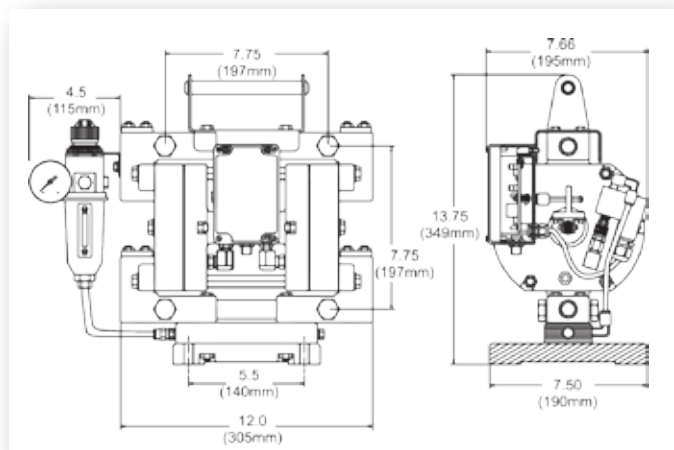
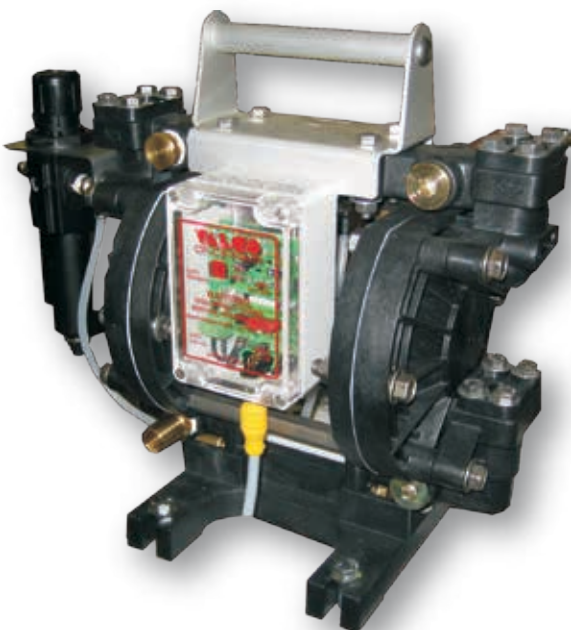
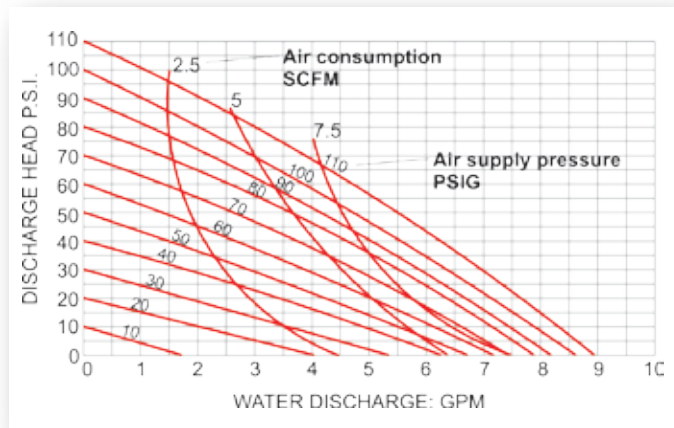

Because of the DD-1 pump's innovative design, it cannot hang up or stall. When used for intermittent output applications, the pump will stop, then immediately restart as the system requires.

The electronic reversing control enables the pump to operate at air pressures as low as 4 psi without getting stuck. This can offer significantly reduced air consumption. It also permits very slow cycling for applications where demand is low, when pumping viscous materials, or when the material being pumped requires delicate handling.

The DD-1 comes standard with Teflon® diaphragms and ball-check valves, which provide excellent suction-lift capabilities and ensure that the pump is able to handle a range of materials, including abrasive and corrosive compounds. Other diaphragm and ball-check materials are available for special applications.

Two Pumps in One

DD-1 pumps can be selected so that each diaphragm chamber is a single-acting pump (two separated inlets/two separated outlets). One pump can be used for applications that would normally require two pumps. It can supply two different liquids to different reservoirs, mix two materials, or be used for a closed-loop recirculating system with one side pumping fluid to a reservoir and the other side pumping away from the reservoir.

Fast, Simple Maintenance

Valco Cincinnati's diaphragm pumps are engineered to keep downtime at a minimum. With externally accessible check valves and a two-piece shaft that provides access to individual diaphragm chambers, the entire pump can be serviced without being removed from the piping system.

Electronically-Balanced Flow Rate

Because of its electronic reversing control, the DD-1 has a unique advantage over any other diaphragm pump: The stroke can be offset electronically so that the output from one side is as much as 50 percent greater than the other. For closed-loop recirculating systems, the pump can be set so that the amount of fluid supplied is less than the amount being pumped away - the reservoir never overfills.

Versatile

The DD-1 pump is truly the most versatile pump on the market today. The unique electronic reversing control opens the door to custom and specialized requirements that are not possible with conventional air-powered pumps. For example, the pump can interface with other controls or data systems to provide automatic usage readout, metered outputs, and automatic level control.

A variety of dispensing solutions in one place.

Contact Valco Melton for all your pumping system needs. We can supply drum covers and mounting brackets to simplify your installation. We also offer pressure hoses, regulators, gauge and gauge protectors, filters, valves, an electronically-reversed 6:1 ratio piston pump, and electronic controls that adapt to meet many requirements.



For more information, visit valcomelton.com or contact your local Valco Melton representative.

World Headquarters: USA, Cincinnati, Ohio (Corporate Offices) • Tel:+1.513.874.6550 • Fax: +1.513.874.3612

Europe Headquarters: Spain, Navarra • Tel:+34.948.321.580 • Fax:+34.948.326.584

Asia Headquarters: China, Xiamen, Fujian • Tel:+86.592.591.7854 • Fax:+86.592.591.7834
info@valcomelton.com • Serving over 76 Countries Worldwide • valcomelton.com