

# **MCP-8I Control Unit**

**Manual Number: MC126**  
**Revision Date: 2/2021**

© 2021 Valco Melton All Rights Reserved

This manual is provided with the MCP-8I Control and may be used only in accordance with the terms of purchase.

No part of this manual may be reproduced, stored in a retrieval system, or transmitted, in any form or by any means, electronic, mechanical, recording, or otherwise, without the prior written permission of Valco Cincinnati, Inc. The information in this manual is furnished for educational purposes only, is subject to change without notice, and should not be construed as a commitment by Valco Cincinnati, Inc.

This manual written and designed at Valco Melton, 497 Circle Freeway Drive, Suite 490, Cincinnati, Ohio 45246.

<http://www.valcomelton.com>

Part Number: MC126

Written and printed in the USA.

**Valco Cincinnati, Inc.**

497 Circle Freeway Drive

Suite 490

Cincinnati, OH 45246

Tel: (513) 874-6550

Fax: (513) 874-3612

Email: [sales@valcomelton.com](mailto:sales@valcomelton.com)

Web: <http://www.valcocincinnatiinc.com>

**Valco Cincinnati Limited**

Hortonwood 32

Telford, TFI 7YN, England

Tel: (+44) 1952-677911

Fax: (+44) 1952-677945

Email: [sales@valco.co.uk](mailto:sales@valco.co.uk)

Web: <http://www.valco.co.uk>

**Valco Cincinnati GmbH**

Bonnerstrasse 349

40589 Dusseldorf-Benrath, Germany

Tel: +49 211 984 798-0

Fax: +49 211 984 798-20

**Melton S.L.U.**

Pol. Industrial Agustinos

calle G, n. 34

31160 Orcoyen, Navarra, Spain

Tel: (34) 948-321-580

Fax: (34) 948-326-584

**Valco Melton France**

Technoparc des Hautes Faventines

32 Rue Jean Bertin

26000 Valence

Tel: +33 (0)4 75 78 13 73

Fax: +33 (0)4 75 55 74 20



# Declaration of Conformity

(According to EN 45014)



The following declaration is issued under the sole responsibility of the manufacturer:

**Manufacturer:** Valco Melton  
A division of Valco  
Cincinnati, Incorporated  
411 Circle Freeway Drive  
Cincinnati, OH 45246  
USA

**Authorized Representatives in Europe:** Valco Cincinnati, Ltd. Melton S.L.U.  
Unit 7-8 Pol. Industrial  
Hortonwood 32 Agustinos  
Telford TF1 7YN England calle G, n. 34  
31160 Orcoyen  
Navarra, Spain

*declares that the product:*

**Product Name:** MCP-8I Control Unit

complies with the following Council Directives:

**Safety of Machinery:** 2006/42/EC

**Low Voltage Equipment:** 2014/35/EU

**EMC:** 2014/30/EU

**Reduction of Hazardous Substances (RoHS)** 2011/65/EC

*and conforms to the following standards:*

**Safety:** EN60204-1:2006  
EN13849-1

**Risk:** ISO12100:2010

**EMC Emissions:** EN61000-6-4:2007  
EN61000-4-2

**EMC Immunity:** EN61000-6-2:2005  
EN61000-4-3  
EN61000-4-4  
EN61000-4-5  
EN61000-4-6  
EN61000-4-8  
EN61000-4-11

**Place and Date:** Cincinnati, Ohio USA  
CE Mark first fixed 2006

**Signature:** Cincinnati, OH USA  
David H. Swedes,  
Vice President of  
Engineering & Manufacturing

This Declaration of Conformity has been generated electronically and is legally binding without signature



---

# Table of Contents

---

<b>Table of Contents .....</b>	<b>5</b>
<b>Section 1 - Introduction .....</b>	<b>9</b>
System Description.....	9
Features/Capabilities .....	9
<b>Section 2 - Safety and Use .....</b>	<b>11</b>
Read Thoroughly Before Handling Equipment.....	11
Symbols .....	11
Owner Responsibilities .....	12
Limitations of Use .....	12
Installation/Startup/Use Safety Information.....	13
Shut Down Safety Information .....	14
Hot-Melt-Specific, General Safety Information .....	14
What to Do if Contact with Hot Adhesive Occurs .....	15
What to Do if Inhalation of Adhesive Fumes Occurs .....	15
What to Do if Adhesive-Related Fire or Explosion Occurs .....	16
Hose Safety Information .....	17
<b>Section 3 - Basic Features .....</b>	<b>19</b>
MCP-8I Control .....	19
Front Panel.....	19
Unpacking .....	20
Mounting the MCP-8.....	20
Standard Mounting System.....	20
Standard System Mounting Footprint .....	21
Swivel Mount (used with JTS0104).....	22
Swivel Mount Mounting Footprint.....	22
Mounting the Encoder .....	23
Installing the Glue Station.....	24
MCP-8I Connections .....	24
Pinouts, Standard .....	25
MCP-8I Valve Driver Instructions .....	30
Wiring the Scanner Cable .....	30
<b>Section 4 - Programming .....</b>	<b>33</b>
Programming .....	33
The Operator Interface Buttons .....	33
The Status LEDs .....	33
Navigation and Edit Buttons.....	34
Enter Password.....	34

Password Levels .....	35
Level 2 Password Options .....	35
Protected Level Mode .....	35
Main Menu Buttons .....	36
Main Window Inspection Additions .....	36
Single Digit vs. Thumbwheel Edit .....	38
Valve Buttons .....	38
Configuring the Valve/Channel Settings .....	39
Valve Selection .....	39
Valve Type .....	39
Encoder Ratio .....	41
Diagnostic Screen .....	43
Compensation Time .....	44
Parameter/Button Access Configuration .....	47
Jam Detection .....	50
Jam Detection Setup Menu .....	51
Tipsealer .....	52
Reversible Glue Station Setting .....	56
Backup (Archive) .....	57
Replace Micro-SD Card .....	59
Reprogram/Reinitialize .....	60
<b>Section 5 - Operation .....</b>	<b>63</b>
Set the Pattern Menu Information .....	63
Set the Pressures .....	68
Purge and Test Run .....	70
Job Screen .....	71
Loading a Job .....	71
Saving a Job .....	72
Deleting a Job .....	73
Copying a Job .....	73
Archive Screen .....	74
Service Screen .....	75
Inspection Screen .....	76
Overview .....	76
Function Bar Buttons .....	77
Inspection Status Icon .....	77
Inspection Status Information Bar .....	78
Inspection Pattern Graphic .....	79
Inspection Pattern Buttons .....	80
Inspection Volume Bar .....	80
Inspection Learn Process .....	81
Learn Result Messages .....	83
Learn Types .....	84
Sensor Activation Status .....	84
Navigating to a Different Sensor Channel .....	85
Supported Sensor Types .....	85
Inspection Alarm/Error Features .....	85

Inspection Reference Modes (only available for analog sensors) .....	86
Inspection Channel Settings.....	86
Overview .....	86
Sub Menus .....	87
Inspection Diagnostic Screen.....	87
Overview .....	87
Button Features.....	88
Zoom In (+) & Zoom Out (-) .....	88
Pan Up & Pan Down .....	88
Alternative View Button .....	89
Save Button.....	89
Graph Features .....	89
Graph Line Legend .....	90
Screen Info Bar Data .....	90
Sensor Diagnostic Test Modes .....	91
Statistic Screen .....	92
Overview .....	92
Totals Page.....	92
Sensor Pages (X).....	92
Clearing of Sensor Statistics.....	93
Sensor Type Counters .....	93
Screen Navigation.....	94
History Screen Notes.....	95
Overview .....	95
Show Info. Button.....	95
Delete Button .....	95
Sensor Filter Buttons.....	96
Page Buttons.....	96
Message Icons .....	97
Additional Message Info.....	97
Inspection System Settings Menu.....	98
Accessibility .....	98
Sub Menu Screens.....	99
Inspection System Settings Menu - Settings .....	100
<b>Section 6 - Maintenance .....</b>	<b>101</b>
Purging the Adhesive .....	101
Performing Downtime Maintenance.....	101
Flushing the Glue System .....	102
Lubricating the System .....	102
<b>Section 7 - Specifications .....</b>	<b>103</b>
<b>Section 8 - Part Number List .....</b>	<b>105</b>
How to Order Parts .....	105
MCP-8I Unit - Standard, Stand-alone (074XX101) .....	106
MCP-8I Unit - Standard, Stand-alone, for Tri-Valve BoardRunner (JTS0134).....	108
MCP-8I Unit - Remote Base Assembly (JTS0105).....	110
MCP-8I Unit - Remote Base Assembly for TIPSEALER (JTS0135).....	113
Rack Assembly (074XX100).....	116
Recommended Replacement Parts.....	120

---

MCP-8I Unit - Remote Display Touchscreen (JTS0137) .....	121
Cover Assembly (026XX458) .....	123
Recommended Replacement Parts .....	125
Standard Mounting System .....	125
Wiring Diagrams .....	126
FlexoSEAL with MCP-8I, Stand-alone Standard .....	126
<b>Section 9 - Warranty .....</b>	<b>129</b>
Warranty Information .....	129
Cold Glue Equipment and Electronic Controls .....	129
Hot Melt Units, Hoses, Valves, Guns, and Related Equipment .....	129
<b>Section 10 - Service .....</b>	<b>131</b>
<b>Appendix A - Job Charts .....</b>	<b>133</b>



---

# Section 1 - Introduction

---

---

## System Description

---

This manual has been prepared by Valco Cincinnati, Inc. to provide assistance in the installation, operation, and servicing of your MCP-8I Control Unit.

The MCP-8I Control Unit from Valco provides operators with a full-featured affordable solution to adhesive system pattern control. The control features 4-channel operation, multiple glue patterns, and an optional flow control capability. The unit allows program changes and adjustments, so you can get desired results immediately. The control has a compact design and features “plug-and-run” connectors for easy installation and quick start up.

---

## Features/Capabilities

---

The MCP-8I Control Unit works with a variety of Valco’s cold-glue or hot melt adhesive dispensing valves. Features/Capabilities of the MCP-8I Unit include:

- Suited to high-speed converting, such as:
  - folding carton production
  - envelope manufacturing
  - paper-folders
  - book and magazine production
  - bag-making
  - corrugated box making
- Dual-encoder-based or timer mode
- Multi-valve, complex glue pattern capabilities
- “Continuous,” “Stitch” pattern and “Jogg” gluing
- Adjustable minimum speed
- Inch or metric calibration
- CE compliant
- Password protection for key system parameters
- Integral fluid-flow control option (EPC) and external EPC output
- Web break detection option
- Batch count/production count
- Job Storage Memory: Up to 1000 jobs
- Programmable valve output voltages depending upon base unit
- Jam Preventer w/Alarm and relay output



All hardware must be up-to-date for all new functions to work. Please see the Parts List for a compatibility chart.



## Section 2 - Safety and Use

### Read Thoroughly Before Handling Equipment

**WARNING!**











Read and follow all safety precautions, warnings, cautions, and other recommendations in this manual. OTHERWISE, DEATH, PERSONAL INJURY OR EQUIPMENT DAMAGE COULD OCCUR.

Read this entire section before handling the equipment.

### Symbols

The following symbols may be used on the equipment and/or in this manual.

	This symbol represents a <b>Caution</b> or a <b>Warning</b> . <i>Cautions</i> draw special attention to anything that could damage equipment or cause the loss of data. <i>Warnings</i> draw special attention to anything that could injure or kill the reader. Both Cautions and Warnings are placed before the step they apply to.
	This symbol represents a <b>Hot Surface</b> .
	This symbol represents a <b>Puncture Risk</b> . It is usually used in regard to nozzle cleaning appliances and other sharp instruments that can cause puncture wounds and risk exposure to bloodborne pathogens and other debris.
	This symbol means that <b>Working Gloves</b> are required.
	This symbol means that <b>Goggles</b> are required.
	This symbol indicates a Shock Hazard. There is a presence of non-insulated dangerous voltage within the product's enclosure. This voltage may cause electrical shock or fire.
	This symbol indicates the need to Unplug/Disconnect All Power Sources and to let them de-energize before attempting any type of work or maintenance. Remember that there can still be energy in equipment, cords, and wires even when unplugged/disconnected.
	This symbol indicates the need to <b>Lock Out All Power Sources</b> and to let them de-energize before attempting any type of work or maintenance. If power is not locked out, the person working on the equipment may be injured or killed if someone unknowingly switches on the power to the equipment.
	This symbol indicates a Note. Notes point out something of special interest or importance to the reader. They give tips, hints, and information in addition to what is necessary for the step preceding it.

---

## Owner Responsibilities

---

The owner of the equipment is under obligation to manage all safety information. Some examples include:

- Examine all safety materials and documents as well as jurisdictional laws and make certain all laws, recommendations, and other safety/hazard laws, certification requirements, training, and instructions are followed and kept current.
- Maintain all safety materials including tags, labels, documents, and MSDS information. Make certain they are distinct and can be read/understood. Replace any that are dirty, worn, or unreadable.
- Make sure all personnel who will handle, install, maintain, operate, fix, and work around the equipment have ready access to the safety information, training, and equipment according to jurisdictional authorities.

The owner of the equipment is under obligation to make certain that all instructions, requirements, and jurisdictional laws are met. Some examples include:

- Make sure there are regular inspections of equipment and safety devices.
- Have regular safety drills and inspections supervised by the proper authorities.
- Provide all required safety items, first aid equipment, and training.

The owner of the equipment is under obligation to make certain that all personnel who will handle, install, maintain, operate, fix, and work around the equipment are qualified, trained, and up-to-date with all information regarding the equipment. Some examples include:

- Make sure all personnel have the proper safety training, equipment, education, and abilities necessary for the job function according to safety instructions and all jurisdictional laws and regulations.
- It is strongly advised that personnel receive first-responder medical care training in case of burns, medical emergencies, or other injuries. Training should be kept up to date.
- Make sure all personnel understand and can follow safety policies and procedures for the organization as well as for the specific equipment.
- Make sure that all personnel are consistently trained, evaluated, free of alcohol and medications that may impair judgment and reflexes, and are tested for banned substances according to jurisdictional authorities.

---

## Limitations of Use

---

Read this document and all information regarding the equipment before handling the equipment. The intended use of the equipment is stated in Section 1 of this manual.

Do not use this equipment for anything other than its intended use. Do not modify, change, or alter the equipment in any way. If you are unsure of the intended use and the limitations of use for the equipment, contact your Valco Melton Representative before handling the equipment.

---

## Installation/Startup/Use Safety Information

---

Valco Melton hot melt units, cold glue units, controllers, inspection systems and all related accessories have the following universal safety precautions (this is not intended to be an exhaustive list; follow all instructions and safety precautions for the specific type of equipment involved):

**WARNING!**

Only qualified personnel should install the equipment. Valco Melton strongly recommends that a Valco Melton Technician install all equipment. OTHERWISE, DEATH, PERSONAL INJURY, OR DAMAGE TO EQUIPMENT COULD OCCUR.

**WARNING!**

The equipment should be installed so that it can be turned off at a location **away** from the equipment in case of injury, electrical problems, or malfunction. OTHERWISE, DEATH OR PERSONAL INJURY COULD OCCUR.

**WARNING!**

Properly route all electrical wires. Never tamper with equipment. Only use approved and correct voltage, type of current, fuses, and other power supplies. Replace worn cords, hoses, etc. immediately. FAILURE TO OBSERVE WARNING MAY RESULT IN DEATH, PERSONAL INJURY, AND/OR EQUIPMENT DAMAGE.

**WARNING!**

Poor ventilation, smoking, and open flames can cause overheated hot melt to ignite. Adequate ventilation must be provided. Smoking should be prohibited in the immediate vicinity of the molten adhesive. Open flames must be kept away from the area around molten adhesive. OTHERWISE, DEATH, PERSONAL INJURY, OR DAMAGE TO EQUIPMENT COULD OCCUR.

**WARNING!**

Never use any Valco Melton equipment in an explosive environment. Explosive environments include, but are not limited to, solvent-based cleaners or adhesives, explosive materials, radioactive materials, etc. OTHERWISE, DEATH OR PERSONAL INJURY COULD OCCUR.

**WARNING!**

Equipment will start automatically when remotely controlled by triggering devices. Be sure to disable all triggering devices, carefully release hydraulic pressure, and disconnect air pressure before servicing or working near guns, valves, and other triggered devices. OTHERWISE, DEATH OR PERSONAL INJURY COULD OCCUR.

---

## Shut Down Safety Information

---

Valco Melton hot melt units, cold glue units, controllers, inspection systems and all related accessories have the following universal safety precautions (this is not intended to be an exhaustive list; follow all instructions and safety precautions for the specific type of equipment involved):

**WARNING!**

Purge the fluid pressure and the air pressure from the system before disconnecting/disabling any part of the system. OTHERWISE, DEATH OR PERSONAL INJURY COULD OCCUR.

**WARNING!**

Disconnect and lock out all power before maintenance or other need to open the equipment. Only qualified personnel should open and service the control. OTHERWISE, DEATH OR PERSONAL INJURY COULD OCCUR.

**WARNING!**

Equipment may still be energized even if unplugged! When making adjustments or performing checkout procedures, stay clear of any moving mechanical parts and do not touch exposed electrical equipment or electrical connectors. OTHERWISE, DEATH OR PERSONAL INJURY COULD OCCUR.

**WARNING!**

Disconnect/disable all mechanical and/or electrical devices that send activation signals to the gun(s), valve(s), melter pump(s), etc. This includes pattern controls, timers, input/output signals, etc. Only qualified personnel should open and service the control. OTHERWISE, DEATH OR PERSONAL INJURY COULD OCCUR.

**WARNING!**

Disable all triggering devices, relieve all residual pressure (hydraulic and air) and allow adhesive to cool before attempting to disconnect guns, hoses, valves, etc. Only qualified personnel should open and service the control. OTHERWISE, DEATH OR PERSONAL INJURY COULD OCCUR.

**WARNING!**

Never point an adhesive dispensing gun, valve, hose, air hose, or anything else at yourself or another person. OTHERWISE, DEATH OR PERSONAL INJURY COULD OCCUR.

---

## Hot-Melt-Specific, General Safety Information

---

Valco Melton hot melt units have the following universal safety precautions in addition to all other universal precautions previously mentioned (this is not intended to be an exhaustive list; follow all instructions and safety precautions for the specific type of equipment involved):

**WARNING!**

**Never** process any polyurethane reactive (PUR) hot melt or solvent-based material in a Valco Melton unit unless you are certain that the unit is compatible and is marked "PUR"! Read all instructions and MSDS sheets carefully, following manufacturer's instructions, especially regarding heat levels. If you have any question as to the compatibility of a Valco Melton unit for PUR hot melt, call your Valco Melton Representative before attempting to use the unit for PUR or solvent-based materials. OTHERWISE, HAZARDOUS FUMES, EXPLOSION, DEATH, OR PERSONAL INJURY COULD OCCUR.

**WARNING!**

Keep pump cover and electrical enclosures closed except during setup, service, and checkout procedures. OTHERWISE, DEATH OR PERSONAL INJURY COULD OCCUR.

**WARNING!**

People with respiratory problems (e.g., asthma, bronchitis, etc.) should not work in the vicinity of molten adhesive. RESPIRATORY PROBLEMS MAY BE AGGRAVATED BY THE FUMES. Do not wear a face mask when working around molten adhesive. THE MASK MAY TRAP THE FUMES AND DEATH OR PERSONAL INJURY COULD OCCUR.

**WARNING!**

Keep hot melt hoses away from walkways and the moving parts of hot melt systems. OTHERWISE, PERSONAL INJURY OR EQUIPMENT DAMAGE COULD OCCUR.

**WARNING!**

Hot surfaces! Do not touch! Use extreme caution when refilling the unit by hand. OTHERWISE, PERSONAL INJURY COULD OCCUR.

**WARNING!**

Wear protective gloves and goggles at all times around all machinery, especially hot melt. OTHERWISE, SERIOUS PERSONAL INJURY COULD OCCUR.

**WARNING!**

Never use an open flame to heat hot melt components or adhesive. OTHERWISE, DEATH, PERSONAL INJURY, OR DAMAGE TO EQUIPMENT COULD OCCUR.

---

### ***What to Do if Contact with Hot Adhesive Occurs***

---

If hot adhesive comes in contact with the skin, do the following:

**WARNING!**

Do not attempt to remove heated hot melt adhesive from the skin. OTHERWISE, SEVERE PERSONAL INJURY AND DEATH COULD OCCUR.

1. Immediately immerse the contacted area in clean, cold water.



It is strongly recommended that a source of clean, cold water be provided near the hot melt work area.

2. Cover the affected area with a clean, wet compress and call the emergency medical response system (such as 911) immediately.
3. Watch for and treat the subject for signs of shock while waiting for professional help to arrive.

---

### ***What to Do if Inhalation of Adhesive Fumes Occurs***

---

If adhesive fumes are inhaled, immediately follow these steps:

1. Take the victim away from the immediate work area.
2. Provide victim with fresh air.
3. Call the emergency medical response system (such as 911) immediately.

---

**What to Do if Adhesive-Related Fire or Explosion Occurs**

---

During the heating and melting process, the surface of the adhesive will be exposed to air. The mixture of polymer fumes and air can catch fire if the hot melt is overheated.

**WARNING!**

Poor ventilation, smoking, and open flames can cause overheated hot melt to ignite. Adequate ventilation must be provided. Smoking should be prohibited in the immediate vicinity of the molten adhesive. Open flames must be kept away from the area around molten adhesive. OTHERWISE, DEATH, PERSONAL INJURY, OR DAMAGE TO EQUIPMENT COULD OCCUR.

**WARNING!**

Exposed arcing may ignite the fume/air mixture. Shield all electrical equipment from melt fumes to avoid exposed arcing. OTHERWISE, PERSONAL INJURY OR EQUIPMENT DAMAGE COULD OCCUR.

**WARNING!**

Do not use a water extinguisher to extinguish the fire! OTHERWISE, PERSONAL INJURY OR EQUIPMENT DAMAGE COULD OCCUR.

If the hot melt adhesive ignites, promptly perform the following steps:













1. Sound a fire alarm.
2. Evacuate the immediate area.
3. Turn off all local electrical equipment at the source.
4. Leave the area immediately if conditions are unsafe.

If you feel you can fight the fire **safely**, do **one** of the following:

- Smother the fire with a fire blanket.
- Aim a CO<sub>2</sub> fire extinguisher at the base of the flames.
- Aim a dry-powder fire extinguisher at the base of the flames.

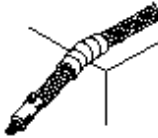

# Hose Safety Information

DO NOT		DO	
<p><b>Do not</b> use bindings, wire ties, or unapproved fasteners around the hoses.</p>		<p><b>Do</b> use approved wrapping (P/N KAP0434), making sure the wrapping is slightly snug but not tight.</p>	
<p><b>Do not</b> place hoses close together.</p>		<p><b>Do</b> allow at least 2 inches (5.1 cm) between hoses for proper ventilation.</p>	
<p><b>Do not</b> bend hoses sharply. <b>Do not</b> allow kinks or indentations in the hoses.</p>		<p><b>Do</b> use a minimum bend radius of 10 inches for a 20-inch diameter coil hose.</p>	
<p><b>Do not</b> use unapproved hooks to hang hoses. <b>Do not</b> wrap hoses over or around objects.</p>		<p><b>Do</b> use a hose hanging kit (P/N 781xx827).</p>	
<p><b>Do not</b> use the "one handed/one wrench" technique to attach or remove hoses. <b>Do not</b> wrench on any surface other than the large hexagon swivel nuts.</p>		<p><b>Do</b> use two hands and two wrenches to tighten or loosen connections on hoses. <b>Do</b> wrench only on large hexagon swivel nuts.</p>	
<p><b>Do not</b> allow hoses to rub against objects or to come into contact with sharp edges or points.</p>		<p><b>Do</b> wrap the hoses in approved padding (P/N 795xx549) if the hoses must be installed where they will come into contact with objects.</p>	
<p><b>Do not</b> use worn, damaged, or bent hoses.</p>		<p><b>Do</b> inspect all hoses regularly for damage and/or wear and replace damaged or worn hoses immediately.</p>	



# Section 3 - Basic Features

## MCP-8I Control

### Front Panel

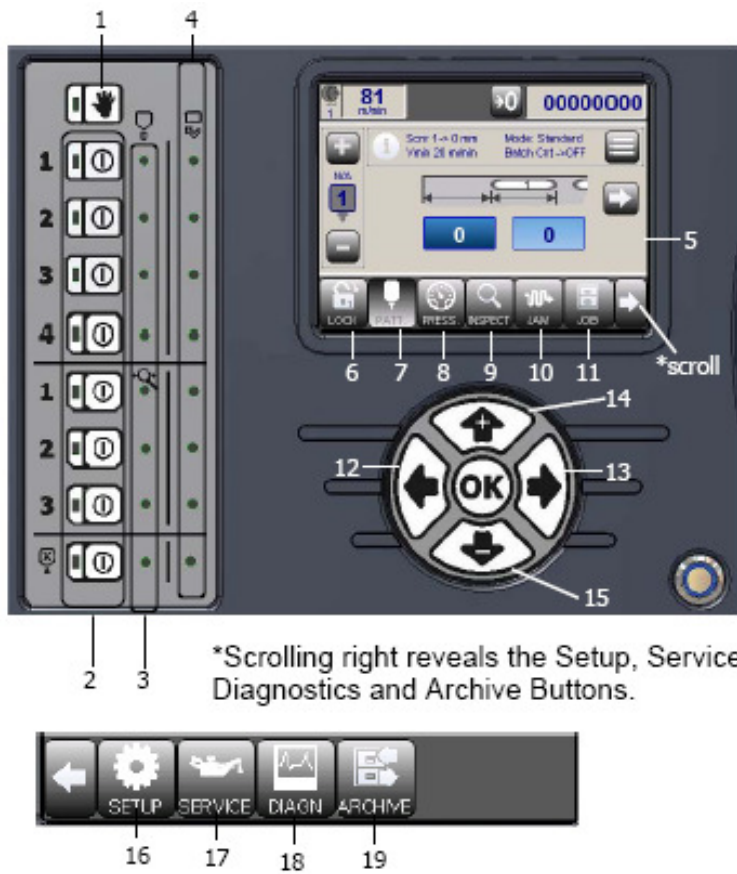

1	Purge Button
2	Valve Enable Buttons
3	Valve LEDs
4	Trigger LEDs
5	LCD Display
6	Lock/Unlock Button
7	Pattern Button
8	Pressure Button
9	Inspection Button
10	Jam Button
11	Job Storage/Recall Button
12	Left Arrow Button
13	Right Arrow Button
14	Plus (+) Button
15	Minus (-) Button
16	Setup Button
17	Service Button
18	Diagnostics Button
19	Archive Button

Figure 3-1. MCP-8I Operator Panel

## Unpacking

Carefully remove the box contents. The contents include the following items:

- MCP-8I Control
- Installation Kit - includes Manual, Quick Start Guide, power cable, 8 mm tube fitting, 1/4-inch tube adapter fitting, and spare fuses.

 Look carefully for small items inside the box! The adapters and fuses are in a small bag. Put them in a safe place for future use.

### CAUTION!



When the display states, "Please Wait..." do not touch any buttons and do not turn off the unit! Information is being retrieved or stored -- and any interruption will corrupt the data.

Follow all safety information carefully. Only qualified personnel should install and service the equipment. Read all safety information in all manuals before working with any equipment.

## Mounting the MCP-8

Depending on the unit, the MCP-8I is mounted using either a Standard mounting system, or a Swivel mount if using remote display touchscreen JTS0104.

The Standard mounting system is used with:

- 074XX101 (stand-alone)
- JTS0104 (remote display)

 This system is used for either wall or panel mounting.

### Standard Mounting System

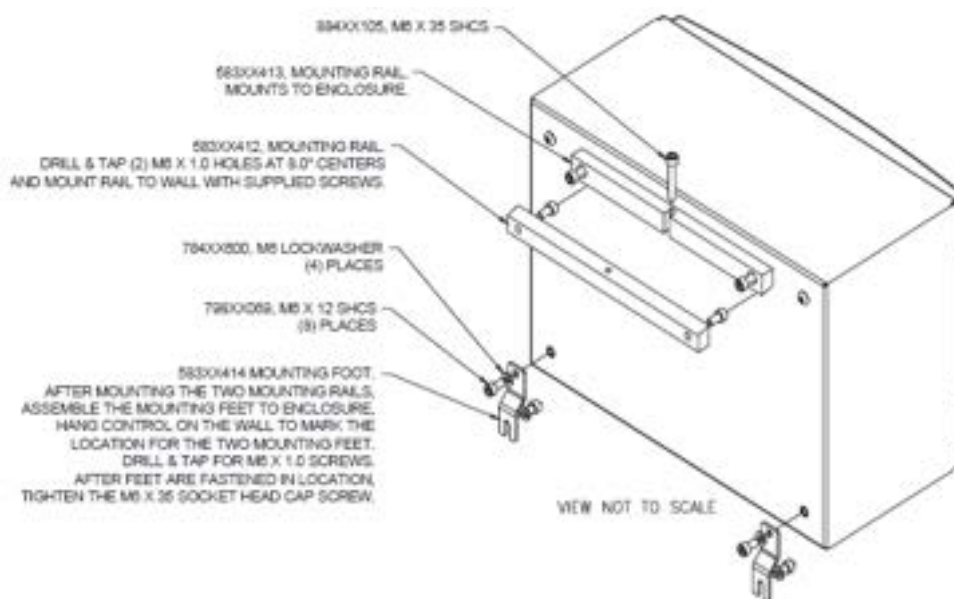

**Figure 3-2. Standard Mounting System**

Standard System Mounting Footprint

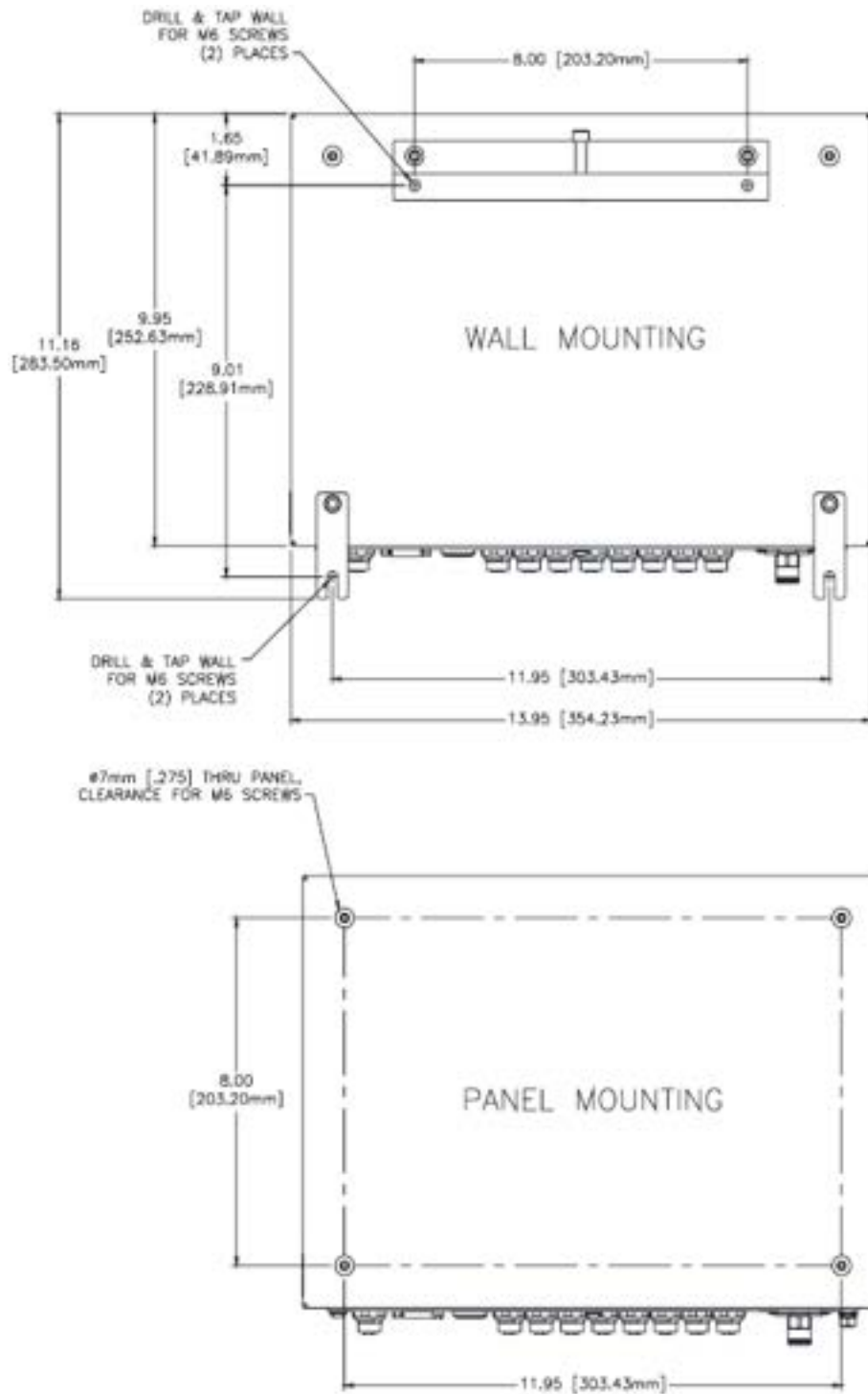
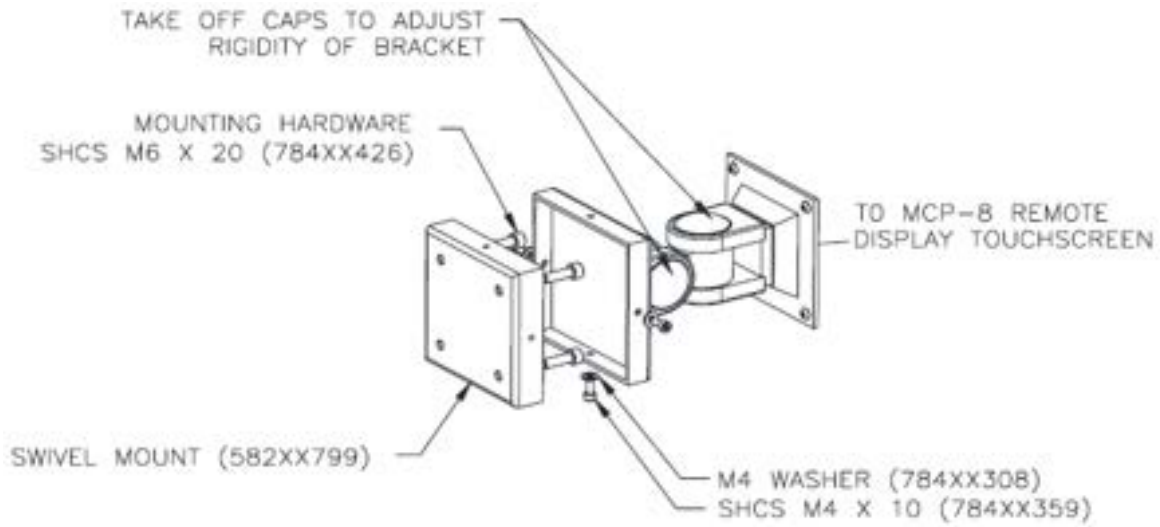

Figure 3-3. Standard Mounting Unit Mounting Footprint

**Swivel Mount (used with JTS0104)**



**Figure 3-4. Swivel Mount**

**Swivel Mount Mounting Footprint**

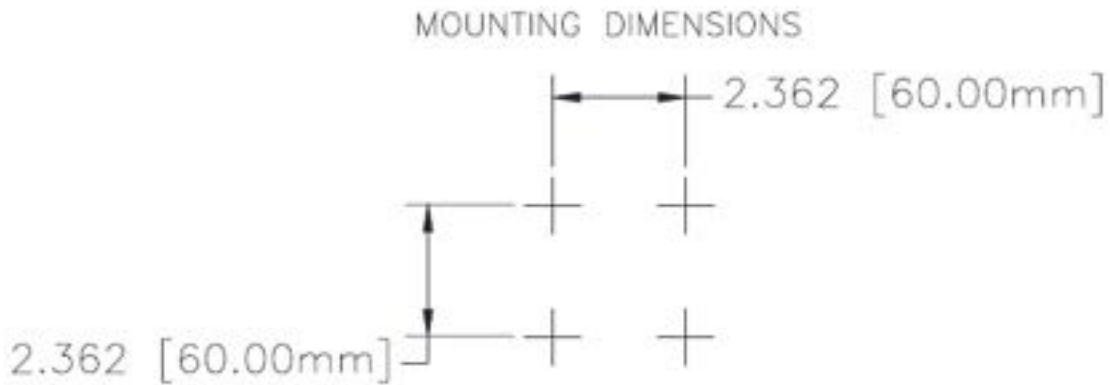

**Figure 3-5. Swivel Mount Mounting Footprint**

# Mounting the Encoder

An encoder must be installed in order for the control to determine the speed of the parent machine. Your MCP-8I Control system can use either a wheel-driven VDD encoder and a measuring wheel or a hollow shaft encoder. For optimal results, use a VDD-1000 encoder for one of the following resolutions: a 10 inch wheel = 100 pulses/inch; a 250mm wheel = 4 pulses/mm.

To install a wheel-driven encoder, follow these steps:

1. Mount the encoder bracket to the frame of the parent machine.
2. Mount the encoder to the bracket and securely affix the wheel.
3. Ensure that the wheel of the encoder rides securely against the belt and does not slip.

**i** For best results, the wheel of the encoder assembly should ride on the bottom side of the belt on the drive side.

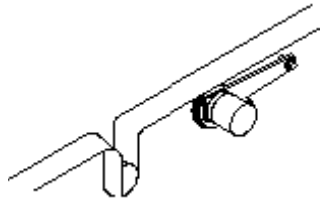

**Figure 3-6. Example of a Wheel-Driven Encoder**

Red Encoder Wheel		
Pulses	Setup	Circumference
1000	Metric	250 mm
	Imperial	9.84 inches
500	Metric	250 mm
	Imperial	9.84 inches
250	Metric	250 mm
	Imperial	9.84 inches

Black Encoder Wheel		
Pulses	Setup	Circumference
1000	Metric	254 mm
	Imperial	10.0 inches
500	Metric	254 mm
	Imperial	10.0 inches
250	Metric	254 mm
	Imperial	10.0 inches

## Installing the Glue Station

Since the MCP-8I is compatible with any glue station, setup may vary depending on cell to gun distance and valves being used. These parameters can be programmed from the front panel of the MCP-8.

To install the Glue Station, do the following:

1. Mount the Glue Station to the parent machine.
2. Install nozzle or applicator head onto the valve if necessary.

 Do not connect the glue hoses at this time. This will be done later in the setup procedure.

## MCP-8I Connections

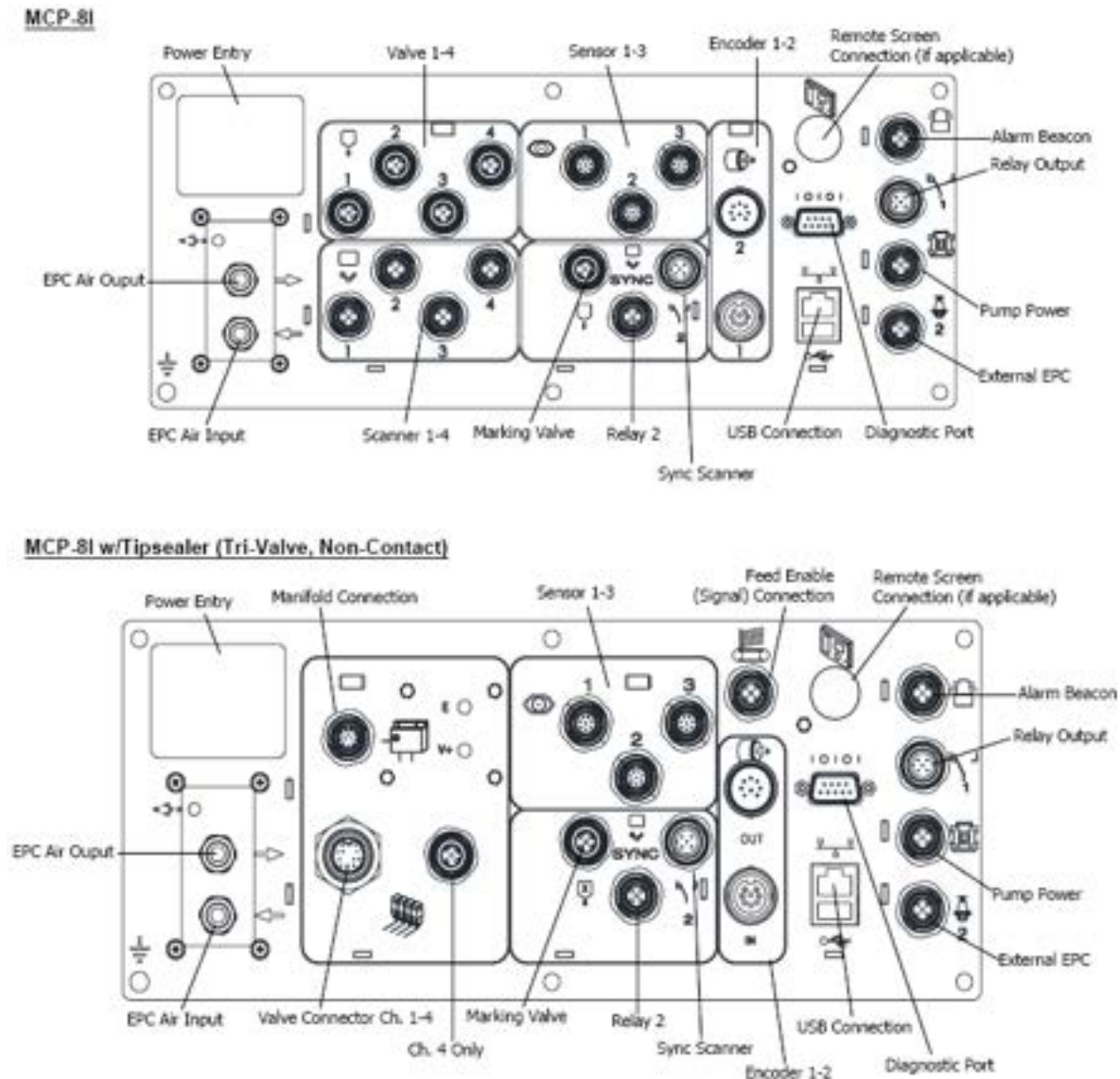

Figure 3-7. MCP-8I Connections



**Pinouts, Standard**

**Valve Output**

Valve Output					
Pin #	Description				Color
	J1	J2	J3	J4	
1	VALV RET1	VALV RET2	VALV RET3	VALV RET4	Brown
2	VALV OUT1	VALV OUT2	VALV OUT3	VALV OUT4	White
3					N/C
4	GND				Blue
5	/PURG1	/PURG2	/PURG3	/PURG4	Black
6	GNDE				Gray

Pinout Drawing					

**Scanner Input**

Scanner Input					
Pin #	Description				Color
	J5	J6	J7	J8	
1	+24V FUSED				Brown
2	SCAN PNP1	SCAN PNP2	SCAN PNP3	SCAN PNP4	White
3	GND				Blue
4	SCAN NPN1	SCAN NPN2	SCAN NPN3	SCAN NPN4	Black
5	GNDE				Gray

  

Pinout Drawing					

**Alarm Beacon**

Alarm Beacon		
Pin #	Description	Color
1	RED ALARM LIGHT	Brown
2	INSPECTION FAULT ALARM BLUE	White
3	GROUND - COM	Blue
4	INSPECTION FAULT ALARM BUZZER	Black
5	JAM FAULT ALARM LIGHT YELLOW	Gray

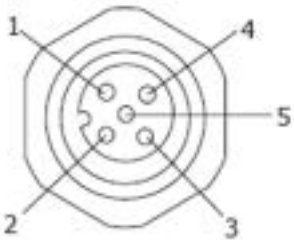

Pinout Drawing		
		

**Encoder (Output/Input)**

Encoder (Output/Input)	
Pin #	Description
1	GND
2	MCP-ENC A+
3	MCP +24V
4	MCP-ENC B+
5	MCP-ENC Z+
6	MCP-ENC Z-
7	MCP-ENC B-
8	MCP-ENC A-

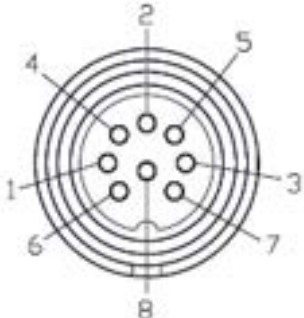

Pinout Drawing	
	

**External EPC**

External EPC		
Pin #	Description	Color
1	+24V FUSED	Brown
2	GND	White
3	GND	Blue
4	SIGNAL	Black
5	GND	Gray

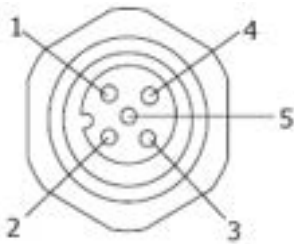

Pinout Drawing

**Diagnostic Port**

Diagnostic Port	
Pin #	Description
1	
2	
3	RX IN
4	
5	TX OUT
6	
7	
8	
9	GNDE

Pinout Drawing

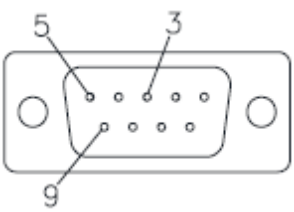
**Sensor**

Type	Sensor Adapter Module
AS301	151xx512
CGS-40	151xx460
Digital	151xx539
CGS40S	151xx739

Pin#	AS301	CGS-40	Digital	CGS-40S	Wire Color
1	AN Signal	AN Signal	IN 1 (NPN/PNP)	AN Signal	White
2	Int. Scanner (NPN)	Int. Scanner (PNP)	IN 3 (NPN/PNP)	Int. Scanner (PNP)	Brown
3	+12v	LED	OUT 1 (NPN/PNP)	LED	Green
4	AN GND	AN GND	IN 2 (NPN/PNP)	AN GND	Yellow
5	+12V	+24V	+24V	+24V	Grey
6	-12V	Int. Scanner (NPN)	OUT 2 (NPN/PNP)	Int. Scanner (NPN)	Pink
7	Detect Line	Detect Line	IN 4 (NPN/PNP)	Detect Line	Blue
8	GND	GND	GND	GND	Red

**Pinout Drawing**

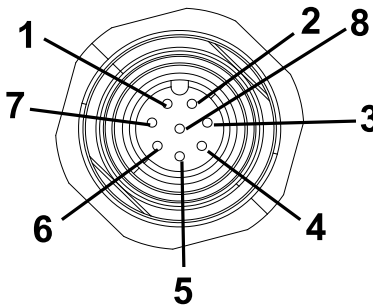

**Relay 1**

Relay		
Pin #	Description	Color
1	COM	Brown
2	N.C.	White
3	N.O.	Blue
4	COM	Black

**Pinout Drawing**

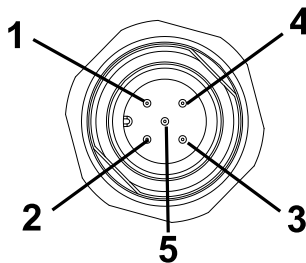

Relay 2

Relay 2	
Pin #	Description
1	COM
2	N.C.
3	N.O.
4	NO CONNECTION
5	NO CONNECTION

Pinout Drawing	

Pump Connector

Pump		
Pin #	Description	Color
1	+24V	Brown
2	GND	White
3	GND	Blue
4	N/C	Black

Pinout Drawing	

---

## MCP-8I Valve Driver Instructions

---

One of three wiring configurations can be used to trigger the valves. Choose the one that best fits the needs of your system. Detailed instructions for each configuration are given in the next section.

**WARNING!**



The triggering device used must be configured to output only 24VDC. If the control unit has a spike, it will damage the input circuit for the scanner.

Disconnect all power and input signal wiring before attempting to install or replace any part of the glue system. Otherwise, personal injury or death may occur!

---

### Wiring the Scanner Cable

---

1. Make sure the MCP-8I power switch is OFF and the unit is unplugged.
2. Cut the female connector off of the Scanner 1 cable.

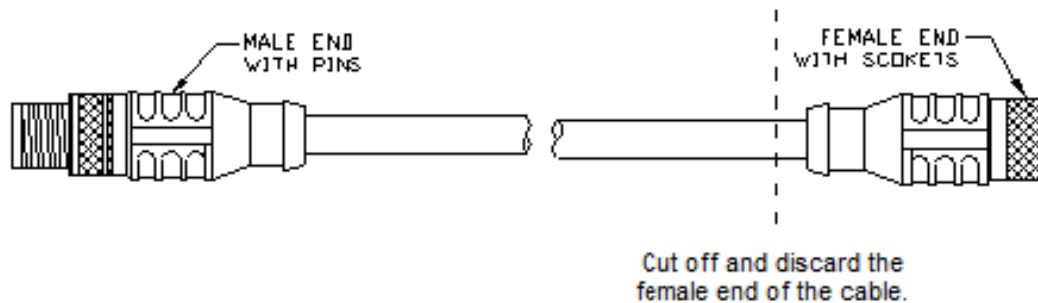

3. Plug the male connector (on the Scanner 1 cable) into the Scanner 1 input port on the back of the MCP-8I Control Unit (refer to Figure 3-7).
4. Carefully strip the scanner cable jacket back and strip the individual wire insulations about 0.25 inch.
5. Wire the modified scanner cable according to the Wiring Diagram (Figure 3-8).

Wiring the Scanner Cable - Continued

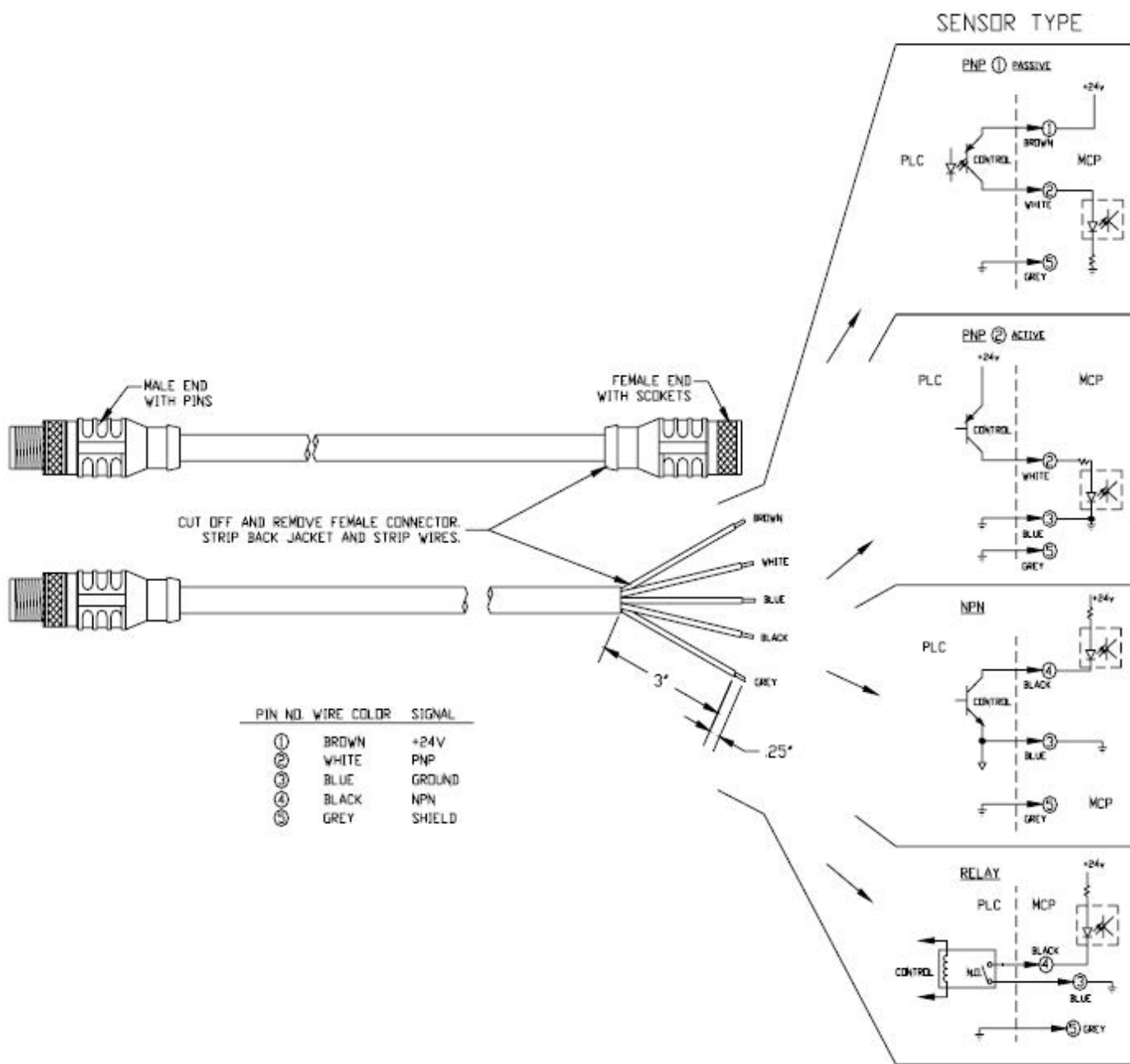

Figure 3-8. Scanner Cable Wiring Diagram





# Section 4 - Programming

## Programming

### The Operator Interface Buttons

Refer to Figure 3-1.

### The Status LEDs

Status LEDs - The Status Display LEDs show on/off status. When an LED is on (lit up), the corresponding input or output is activated (see Figure 4-1).

**CAUTION!**



Be sure the encoder, scanners, valves, and the MCP-8I Control Unit have been properly mounted to the parent machine before setting up the control. The glue and air lines are not connected until after the control is programmed.

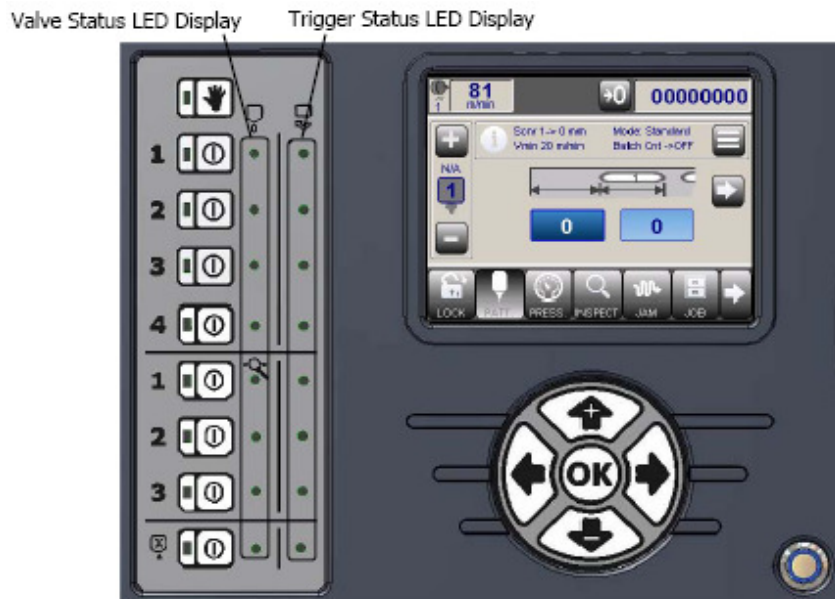

Figure 4-2. Status LEDs

---

## Navigation and Edit Buttons

---

The MCP-8I is a **touchscreen** system, allowing screen buttons/fields to operate when touched. Screen navigation can also be performed using the buttons described below.



There are 2 Navigation Buttons: the Right Arrow Button and the Left Arrow Button.

**Right Arrow Button** - Pressing the Right Arrow Button moves the cursor to the right, highlighting each editable field.

**Left Arrow Button** - Pressing the Left Arrow Button moves the cursor to the left, highlighting each editable field.

There are three Edit Buttons: the Plus Button, the Minus Button and the OK Button. These Buttons are used to change/enter information.

You can only change a value when it is highlighted.

**Plus Button** - Pressing the Plus Button allows you to increase the value of the input.

**Minus Button** - Pressing the Minus Button allows you to decrease the value of the input.

**OK Button** - Pressing the OK Button opens and closes the thumbwheel control. It also “opens” highlighted menu screens for editing.

---

## Enter Password

---

To view, setup, and use the various functions of the MCP-8I Control Unit, passwords are used. This ensures safety and security of all settings. To enter a password, do the following:

1. Referring to the Operator Panel illustration/table on page 33, highlight the Lock/Unlock button (#6) and click OK.
  - a. The Password screen will appear.



2. Enter your password (PIN), and then highlight “UNLOCK.”

*Enter Password - Continued*

3. Click OK.
  - a. The button icon will change to 'unlocked,' and the password level (number) will be displayed.



---

## ***Password Levels***

---

There are five password levels:

### **Level 0: Protected**

When the unit is set to Level 0, only basic pattern settings can be entered or changed. Level 0 provides the ultimate safety settings to prevent unauthorized and/or accidental changes. This level can be set as the "Default" level by someone with a Level 2 (Supervisor) password.

### **Level 1: Operator** (No password required)

This is the "Default" level of operation when the unit is first turned on (unless the "Default" setting has been changed to Level 0 by a Supervisor). Level 1 allows Operators to set patterns, pressures, load jobs, and enter basic parameters necessary to run jobs.

### **Level 2: Supervisor** (Default Password = 1234)

This is the highest user password level. At this level, the "Default" password level can be set, individual valve settings can be viewed and changed, jobs can be saved (as well as loaded), and the memory can be backed up. The Level 2 password can be changed (this is explained under the heading "Level 2 Password Options").

### **Level 3: Service**

This password level is reserved for Authorized Service Personnel.

### **Level 4: Programmer**

This password level is reserved for Factory Programmers.

---

## ***Level 2 Password Options***

---

A Level 2 Supervisor has the ability to place the unit into the Protected Level Mode (Level 0) and to change the Level 2 password.

---

## **Protected Level Mode**

---

The Protected Level Mode (Level 0) increases security by changing the Default Level of the unit from Level 1 to Level 0. This means that when the unit is turned on, it will automatically be in Level 0 instead of Level 1 (until the supervisor changes the Default Mode to Level 1). Only someone with the Level 2 password can change the Default Level of the unit.

---

## Main Menu Buttons

---

There are six Main Menu Buttons (refer to the operator panel illustration/table, Figure 3-1). The “button depressed/normal” appearance of the Buttons indicates which Main Menu Button is selected.

**Pattern Button (#7)** - Pressing the Pattern Button allows you to begin to enter gluing patterns for valves 1-8.

**Pressure Button (#8)** - Pressing the Pressure Button allows you to begin to enter the pressure settings.

**Inspection Button (#9)** - Pressing the Inspection Button allows access to the results and settings for sensor channels 1 to 3.

**Jam Button (#10)** - Pressing the Jam Button allows you to set up the Jam Detection/Alarm parameters.

**Job Button (#11)** - Pressing the Job Button allows you to save a job and load a job.

**Setup Button (#16)** - Pressing the Setup Button allows you to begin to setup the MCP-8I Control Unit.

**Diagnostics Button (#19)** - Pressing the Diagnostics Button allows you to view the MCP-8I Control Unit diagnostics.

---

## Main Window Inspection Additions

---

### The Error Message Banner

The Error Message Banner will appear on top of the encoder status bar whenever an inspection error occurs.

Feature Options:

The message banner will appear to notify the operator if an inspection error has occurred.

The message banner will also detail how many other errors were generated at that time for that inspection channel.

The message banner has a timeout of 3 minutes after closing, to allow access to the encoder status bar and counter information.

The message banner will also appear if an alarm is waiting for a manual reset. Closing the message banner will reset the alarm.

 The manual reset message will appear, regardless of the timeout timer.

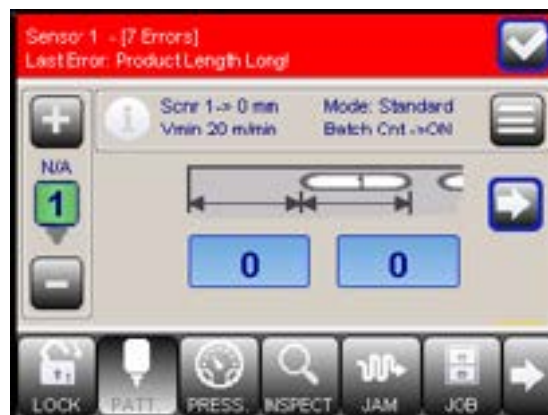

**Inspection Job Counters**

The Job Total Good and Total Bad Inspection counters were added to the encoder status bar to actively see the Job inspection counts. More information relative to the Inspection counters can be found under the Inspection Statistic's Window.

Clicking anywhere in the counter boxes will change the counter display to the next counter display option.



**Inspection Window Access Button & Window navigation**

The Inspection window is accessible by pressing the "INSPECT" button.



Once the inspection window is shown, pressing the back button will return the function bar to its original state and allow access to navigate to other main windows.



**i** Regardless of if the Inspection Window is still shown or not, pressing the "INSPECT" button will bring the Inspection Window function bar buttons back into view.

## Single Digit vs. Thumbwheel Edit

When editable information is numerical, the information may be edited with the Plus/Minus Buttons for single digit editing, or the OK Button may be pressed to bring up a thumbwheel for more detailed editing using the Plus/Minus Buttons.

In thumbwheel editing, “Cancel” closes the thumbwheel edit window, abandoning any changes. “Clear” clears all digits to zero. “Apply” confirms the new settings and closes the thumbwheel edit window.

 Press the Right or Left Arrow Buttons until you highlight the desired key, and then press OK to select it.

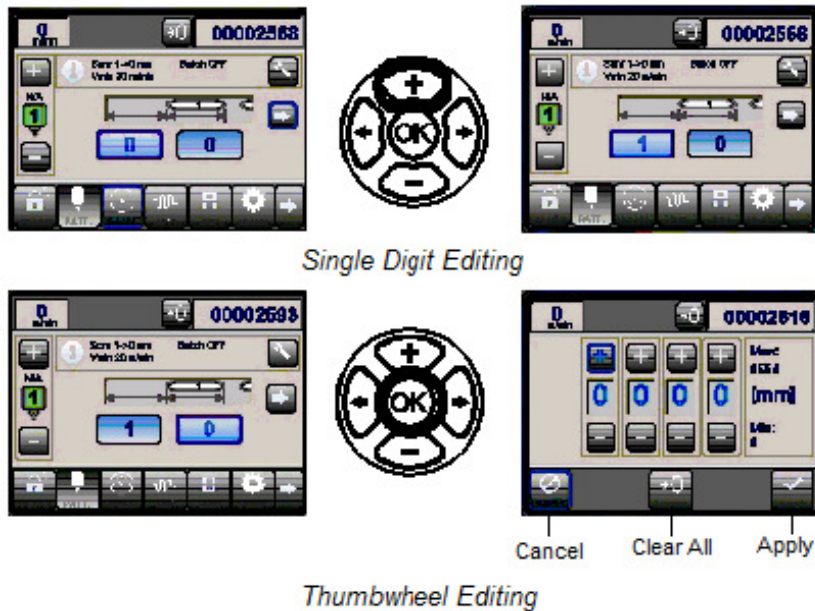

## Valve Buttons

There are 9 Valve Buttons: the Purge Button and Valve Buttons 1 through 8.

Pressing the Purge Button allows you to turn the Manual Purge Mode on and off.

 When the Purge Button LED is on, Manual Purge Mode is on. In this Mode, the Valve Buttons act as “purge buttons.” When the LED is off, the Valve Buttons turn the valves on and off.

Pressing the individual Valve Button(s) WHEN THE MANUAL PURGE BUTTON IS NOT ILLUMINATED tells the MCP-8I control which valve you are going to use for the job you will run. The LED in the upper Left hand side of the Buttons indicates which valve is selected.

## Configuring the Valve/Channel Settings

The settings are preprogrammed for the specific application selected. It is best not to change any setting unless you are a trained technician and/or have assistance from a member of the Valco Technical Assistance Team.

**CAUTION!**



Changing settings may bring unwanted consequences in the performance of your system. Valco Cincinnati, Inc. recommends having a qualified technician setup your system parameters. Otherwise, loss of production time may result from improper settings.

 All screens for configuring the valves/channels are available in all applications.

### Valve Selection

The Valve Selection Keys allow the operator to scroll between active valves. The selected valve number and type are displayed. Use the arrow keys to highlight “+” or “-”, and then press OK to scroll.

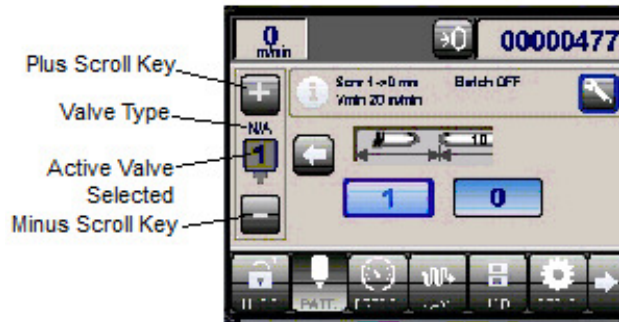

### Valve Type

To set the valve type for each valve, proceed as follows:

1. Highlight the Valve Settings Key, and then press OK.



Valve Type - Continued

The drop down menu will allow three selections:

- Copy
  - Delete
  - Setup
2. Highlight "Setup," and then press OK.



The setup menu for the selected valve number will open.

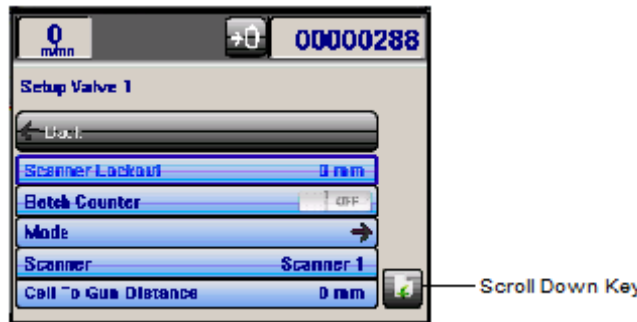

3. Using the Arrow Buttons, scroll to the 'Scroll Down Key, and then use the Minus ("-") button to scroll down to "Valve Type."
4. Press OK twice to access the Valve Type menu.



**i** If the default valve type that appears is "not applicable" (N/A), use the Plus/Minus buttons to scroll through the list of valve types available.

5. Set the highlighted valve type by highlighting "Apply" and clicking OK.



Valve Type - Continued

 Selecting “Cancel” closes the menu without changing the valve type.

- 6. Set the valve type for each valve, as needed.

---

### Encoder Ratio

---

The encoder ratio is the number of encoder pulses, for the product travel length, per encoder rotation,  
To input Pulses:

- 1. Highlight the General Setup Button .
  - a. The General Setup Menu will open.



- 2. Highlight the Encoder you wish to edit, and then press OK.
  - a. The Encoder Setup Menu will open.

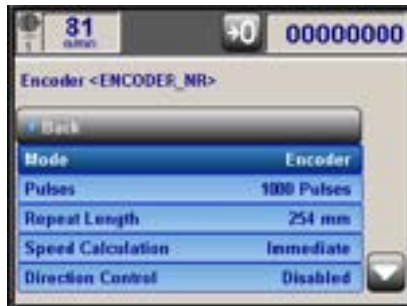

To edit Pulses:

- 3. Highlight “Pulses,” and then press OK.
  - a. The Pulse Edit Screen will open.



Encoder Ratio - Continued

4. Use the Arrow Buttons to highlight the “plus” or “minus” key for the digit you wish to edit.
5. Use the Plus and Minus buttons to change the setting.
6. When all digits have been edited as desired, use the Arrow Keys to highlight “Apply,” and then press OK.

To edit Repeat Length:

7. Highlight “Repeat Length,” and then press OK.
  - a. The Repeat Length Edit Screen will open.



8. Use the Arrow Buttons to highlight the “plus” or “minus” key for the digit you wish to edit.
9. Use the Plus and Minus buttons to change the setting.
10. When all digits have been edited as desired, use the Arrow Keys to highlight “Apply,” and then press OK.

The following tables may be helpful:

Red Encoder Wheel		
Pulses	Setup	Circumference
1000	Metric	250 mm
	Imperial	9.84 inches
500	Metric	250 mm
	Imperial	9.84 inches
250	Metric	250 mm
	Imperial	9.84 inches

Black Encoder Wheel		
Pulses	Setup	Circumference
1000	Metric	254 mm
	Imperial	10.0 inches
500	Metric	254 mm
	Imperial	10.0 inches
250	Metric	254 mm
	Imperial	10.0 inches

 To test the encoder ratio, refer to the *Diagnostic Screen*, below. A recommended guideline: the number of pulses should be consistent for each product run, within approximately 3%. A greater fluctuation may indicate the product is slipping during transit, creating a false length reading.

### Diagnostic Screen

Selecting the Diagnostic Button opens the Diagnostic Screen.

The top screen section displays the software version information, while the bottom section displays the valve status. The top numbers show the valve type. The bottom numbers will switch back and forth from showing the valve voltage to showing the valve status (enabled or disabled).



Diagnostic Button

 A voltage reading of 0.0 could indicate a blown fuse. See the Parts List section for fuse numbers and placement.

Scrolling down, The “Scanner” display indicates the number of encoder pulses that occurred while the scanner was blocked. This is a useful reference for determining the encoder ratio accurately (number of pulses compared to product length).



---

## Compensation Time

---

To access Compensation Time Settings:

1. Highlight the Valve Settings Key, and then press OK.



The drop down menu will allow three selections:

- Copy
- Delete
- Setup

Highlight "Setup," and then press OK.



The Valve Setup list menu will open.



Compensation Time - Continued

2. Scroll down to “Ton,” “Toff,” or “Tmin” as required (see below).



**On Compensation Time (Ton)** - This is the amount of time (in milliseconds) from when the valve is activated to when the glue is applied. Increasing the "ON" Compensation Time will move the start of the pattern forward.

**Off Compensation Time (Toff)** - This is the amount of time (in milliseconds) from when the valve is turned off to when the adhesive application is stopped. Increasing the Off compensation time will make the glue line shorter.

**Minimum Compensation Time (Tmin)** - This is the time the valve will be open, no matter what the pattern length, the machine speed, and the "OFF" Compensation Times are set at.

Ton and Toff are determined by running the machine at slow speed, checking glue pattern placement, and then running the machine at high speed and checking glue placement.

If the pattern moves forward on the sheet, the compensation time is too high.

If the pattern moves back on the sheet, the compensation time is too short.

Ton affects the beginning of the pattern. Toff affects the end.

**CAUTION!** These parameters can be adjusted only if the machine can be run both at high and low speed, and should not be adjusted without performing this test.



3. Highlight the General Setup Button.
  - a. The General Setup Menu will open.



4. Highlight the Encoder you wish to edit, and then press OK.
  - a. The Encoder Setup Menu will open.

## Compensation Time - Continued

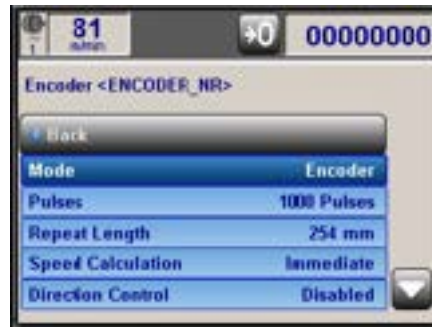

5. Highlight "Speed Calculation," and then press OK.
  - a. The Speed Calculation Edit Screen will open.



 When set to "Average 1," the speed calculation only affects the Transducer output. "Average 2" affects the Transducer output and Valve compensation.

6. Highlight the desired setting.
7. Highlight "Apply," and then press OK.

"Immediate" is helpful if the machine starts and stops often, with products in the machine.

If the MCP-8I was set to speed averaging, and the machine restarted with a product directly in front of the valve, that box may not be glued, because the control did not think the machine was up to speed by the time the product reached the scanner for that valve.

If a machine runs at a steady speed, with little change, averaging will be a better choice to compensate for minor speed variations, due to measurement error in the encoder wheel.

# Parameter/Button Access Configuration

This feature allows you to customize the control display, hiding buttons that are not typically accessed by the operators, to prevent confusion and improve the user experience. For example, if the machine has a fixed repeat, there will likely be no need to change the jam length often.

**CAUTION!** Configuration changes should only be made by authorized Valco Melton personnel.



**i** Level 4 (Programmer) cannot be reconfigured.

To configure parameters or buttons:

1. Select the Lock button.



2. Enter the Level 4 password for configuration access.

**i** A "C" appears in the Lock icon.



In this configuration mode, selecting a parameter/button opens a menu that allows the programmer to designate one of the following settings:

**Parameter:** Enable; Hide; Disable

**Button:** Enable; Hide

Parameter/Button Configuration – Continued

Example:

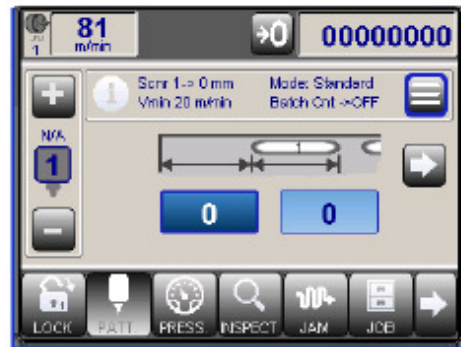

Selecting the Pattern Menu Setup Button opens "Define User Access" screen



"Define User Access" screen allows level selection



Menu allows configuration selection of for the selected access level (for this example: "Hide")

"Allow" confirms the change

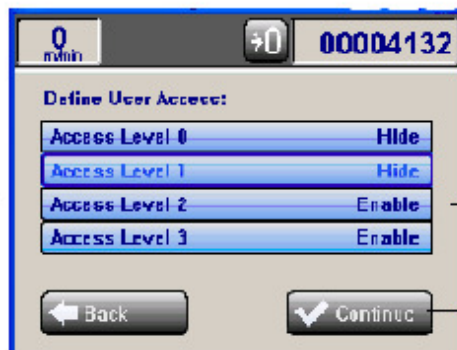

"Define User Access" screen displays new settings

"Continue" confirms all changes



Parameter/Button Configuration - Continued



**i** When changing a Parameter access configuration, an option is included for changing either an individual channel, or ALL channels.

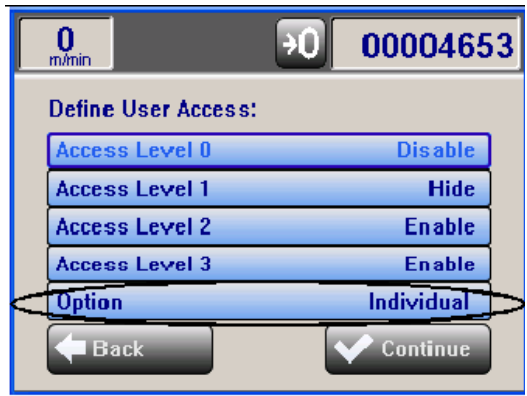

Option for changing either an Individual channel, or ALL channels (click to open selection window, below).

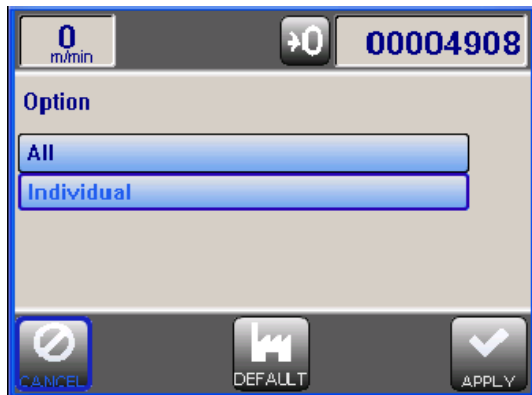

## Jam Detection

Selecting the Jam Detection Menu Button opens the Jam Detection Menu.

Jam Detection, sometimes called Jam Prevention, can stop the machine before a jam occurs. Jam prevention works by measuring the scanner activation length. If the product is double feed, then the scanner will measure the product as being too long and stop the machine. This prevents a jam from occurring when the sheet is folded and stacked. Jam detection can also stop the feeder, minimizing the magnitude of any jam that occurs. It can also measure if the flap on folded boxes has been folded back correctly.

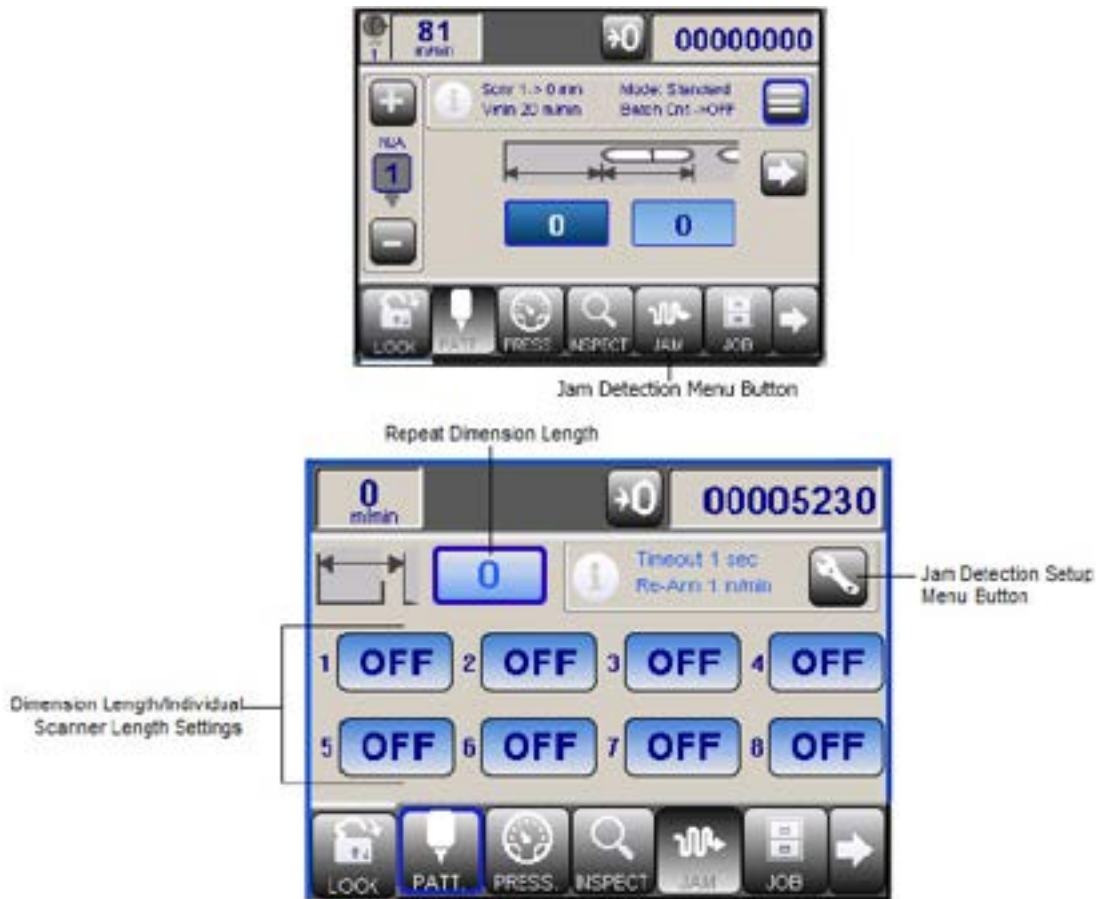

### Dimension Length/Individual Scanner Length Settings:

Set an individual detection length for each active scanner. When the scanner detects any product longer than this length, it will signal a jam. A recommended starting point would be box length plus 20%.

### Repeat Dimension Length:

Use to set the Dimension Length for all scanners that are on (must press the Apply Button for this to take effect).

### Jam Detection Setup Menu Button:

Opens Jam Detection Setup Menu.

**Jam Detection Setup Menu**



**Threshold Speed:**

The active scanners will not scan for jams until the machine is running at or above this speed. The speed is measured in meters per minute or feet per minute.

**Timeout:**

Indicates a “forced-stop” time (1-10 seconds) before system can be restarted.

**Output 1:**

On or OFF

**Output 2:**

On or OFF

**Function:**

For either Output, includes the following options:

**Off**

**Alarm 1**

**Alarm 2**

**Relay**

These refer to the relay outputs on the control. For connections, refer to Section 3.

**Mode:**

For Output 1 only, includes the following options:

**Wait V=0:**

After a jam condition has been cleared, the system looks for input “0” (jam signal has been ‘lost’) to signal it can be restarted.

**Continue:**

System looking for Encoder input.

# Tipsealer

The Tipsealer function places the nozzles onto the Tipsealer Pad during brief workflow stops, to prevent the glue from drying out.

**i** Tipsealer Control supports 3NC, 4NC, 3NCR and 4NCR glue stations (3NCR and 4NCR are reversible). This is only available on Tri-Valve MCP-8I controls.

Selecting the Setup Menu Button opens the Setup Menu.



On the Setup Menu, make sure the Application is set to “Corrugated.”

**i** The factory-default application setting is “Folding Carton,” which does not employ the Tipsealer feature. The application must be set to “Corrugated” to access the “Glue Station Setup.”

Press “Glue Station Setup” to select.

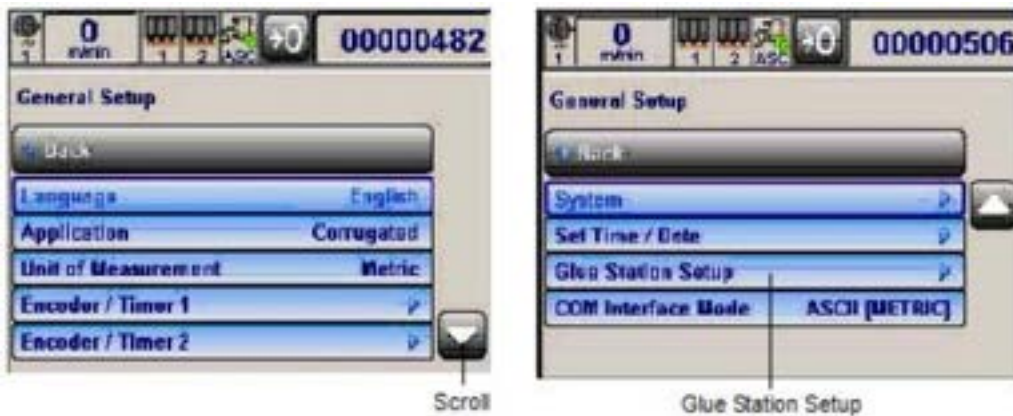

*Tipsealer - Continued*

Select the Glue Station Type, either Operator Side (OS) or Drive Side (DS), that you wish to configure.



When the station is selected, a sub-menu will open, allowing selection of a specific configuration to match the system. Select the desired configuration and touch "Apply."



**Tipsealer Control:**

Allows settings to be turned on or off by pressing the command. When turned on, options below "Tipsealer Control" will be accessible. In addition, the icon will show if the valves are in the tip sealing position or in the run position.



**Feeder Timeout:**

When the Feeder is stopped, a programmed timeout (from 5 to 60 seconds duration) delays station movement to or from the tipsealer pad. If the Feeder is restarted before the timeout ends, the valves remain in the dispensing position.

**Feed Signal Polarity:**

Allows the following Feed Signal options (polarity):

**N.O.**

Feeder is Normally Open (Off).

**N.C.**

Feeder is Normally Closed (On).

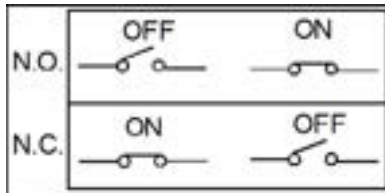

If the Valves move to the Tipsealer Pad when the Feeder is Active (ON), or move to the dispensing position when the Feeder is Off, the polarity is incorrect.

Reverse the polarity setting to correct it.

**Delay Time (1-4):**

These settings, designated by number (1-4), set the delay (in milliseconds) for each valve motion to or from the Tipsealer Pad (refer to the figure, below).

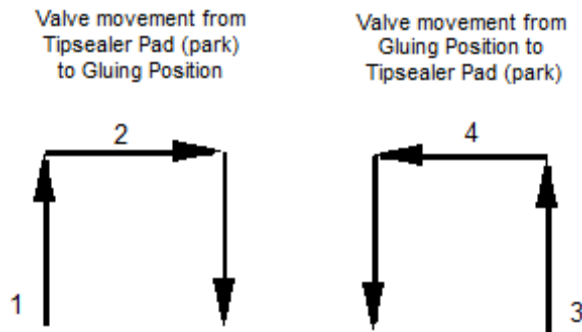

**Output Manual Mode:**

When the station is switched to Manual Mode, the controls allow an alarm to activate, or for a relay to shut down the system until the station is set back to Auto Mode.

The Manual Mode function allows to operator to manually move the valves off the Tipsealer to clean the nozzles. If the manual mode switch is not set back to auto, the Tipsealer will be disabled during future machine stops. The Manual Mode button is located on the air manifold control box, located near the glue station.

Manual Mode output options:

**Off**

**Alarm 1**

**Alarm 2**

**Relay**

*Tipsealer - Continued*

**Output Error Mode:**

When an error occurs, the controls allow an alarm to activate, or for a relay to shut down the system until the error is corrected and the system restarted.

Error Mode output options:

**Off**

**Alarm 1**

**Alarm 2**

**Relay**

**Jogg on Restart:**

“Jogging” dispenses a series of glue dots, rather than a continuous line. This helps to clear the nozzles of dried glue and make sure the valves are dispensing correctly. “Jogg on Restart” sets the number of boxes (0-25) that will receive a “jog” pattern, following a restart, before glue again dispenses in the normal, programmed pattern.

### Reversible Glue Station Setting

When a selected glue station offers both top-down and bottom-up operation (example: "FLIP 3"; "FLIP 4"), a Reversing Button appears.

When this button is pressed, the control automatically re-programs the patterns for correct glue placement, according to their location and the cell-to-gun distance setting.



The screen will now indicate that the station setting has been reversed.



**CAUTION!**



Selecting a Glue Station Type does not set a reversible station to the correct system configuration automatically. The Reversible Gluing Button must still be used to set the station for top-down or bottom-up gluing.

**i** If the glue lines are being dispensed in a 'staggered' pattern (see below), the Reversing Button must be pressed to correct the dispensing order.

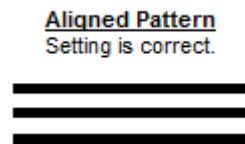
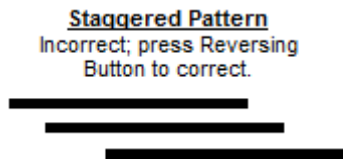



# Backup (Archive)

Before removing the Micro-SD card, backup your settings.

 The Archive Button is not accessible at all levels.

1. Press the Archive Button on the MCP-8I screen.

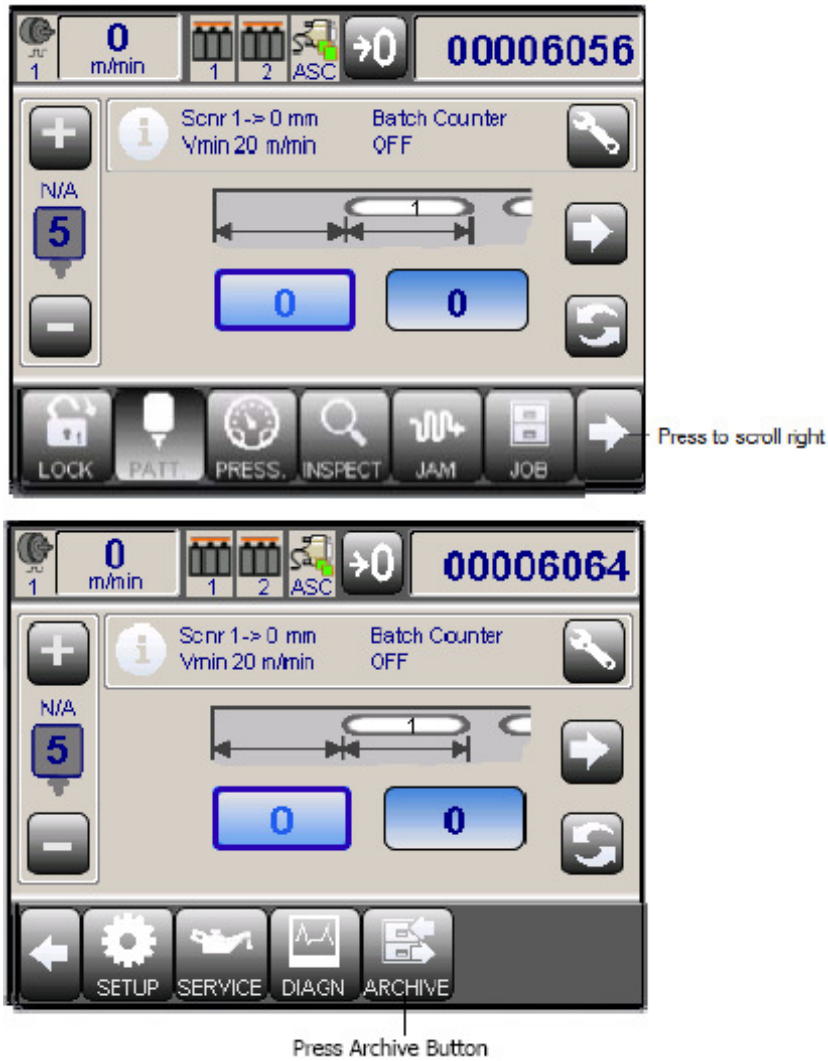

Backup (Archive) - Continued

2. Press the Backup Button.



3. Using the keypad, enter a name for the setup you are saving.



4. Press Backup to confirm and save.



5. Turn the control unit OFF.

---

## Replace Micro-SD Card

---

1. Loosen the four (4) screws holding the control cover.



2. Locate the Micro-SD Card.

Micro-SD Card and Holder

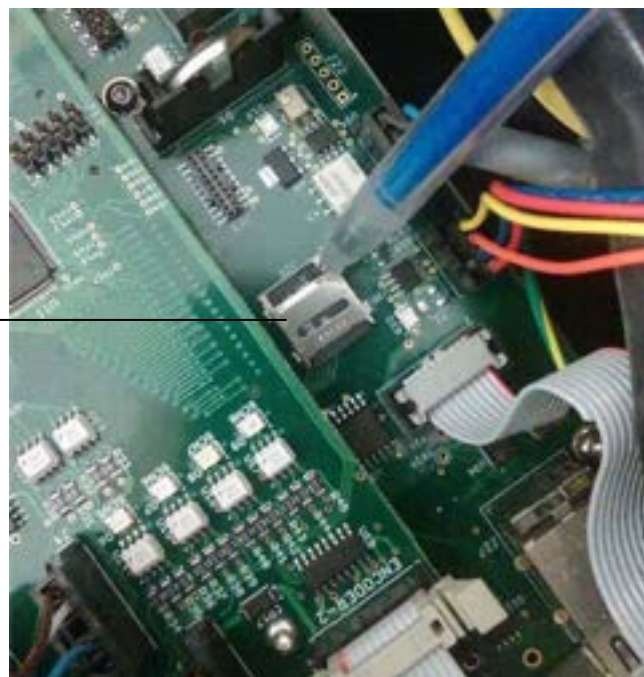

*Replace Micro-SD Card - Continued*

3. With a fingertip, slide the card holder in the direction shown by the arrow to release the holder cover.
4. Lift the holder cover.

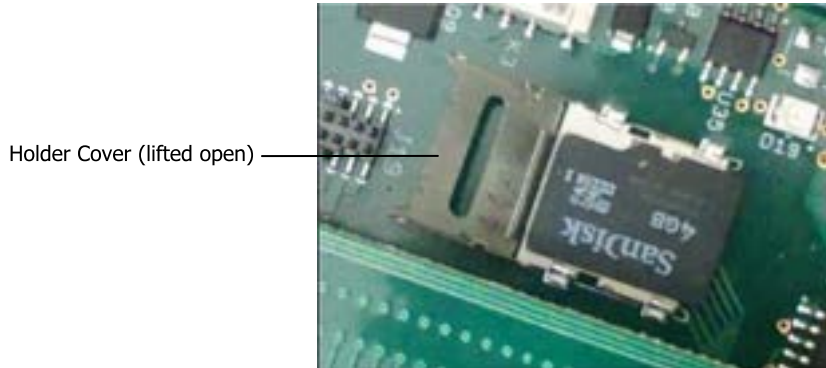

5. Remove and replace the Micro-SD Card.
6. Close the holder cover.

**CAUTION!** When closing the cover, make sure the Card stays in the correct position. If the card moves out of position, it may not connect properly.



7. Re-lock the cover by sliding the holder back to the home position.
8. Replace the Control Unit Cover and screws.

---

## Reprogram/Reinitialize

---

 A USB Flash Drive for reprogramming will be found in the installation kit.

1. Insert the programming USB Flash Drive.



2. Turn the unit ON.

 The system will take approx. 1 min. to reprogram before the screen will appear.

Reprogram/Reinitialize - Continued

- 3. Access the Archive Screen.
- 4. Highlight the backup file you created earlier, and press the Restore Button.

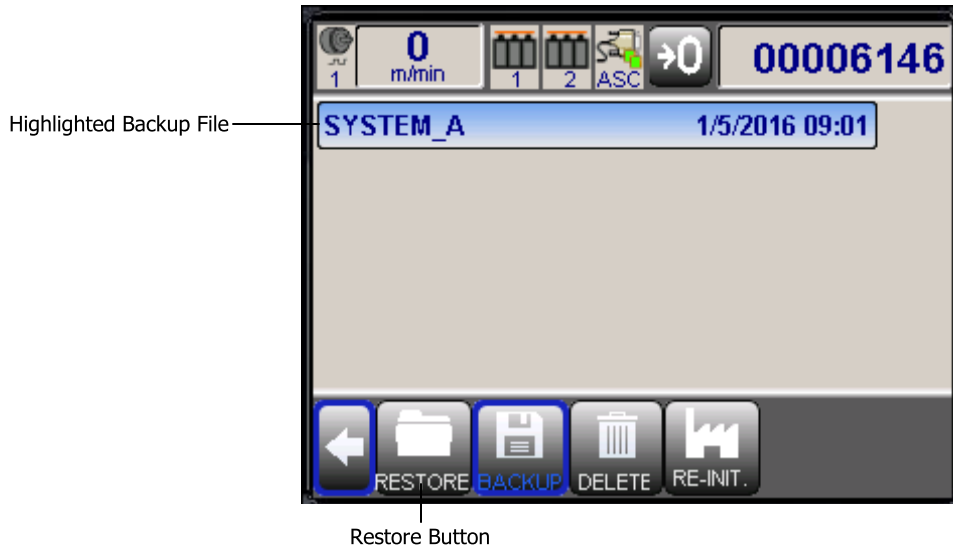

- 5. At the prompt (Figure 10), press "YES" to confirm restoring the backed-up settings.

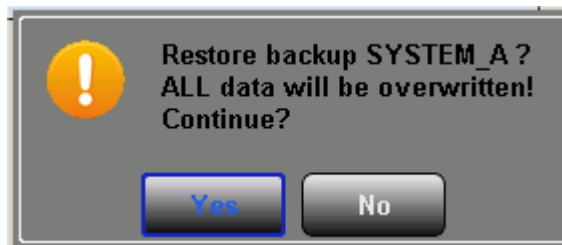

- 6. Turn the unit off and remove the programming USB flash drive.
- 7. You have completed the procedure.



# Section 5 - Operation

## Set the Pattern Menu Information

After completing the mounting and the programming of the MCP-8I Unit, the unit is ready to operate. The first task is to input all pattern data and other essential information.

 Depending on the password level, some screens may not be seen and/or available. This is a security feature of the MCP-8.

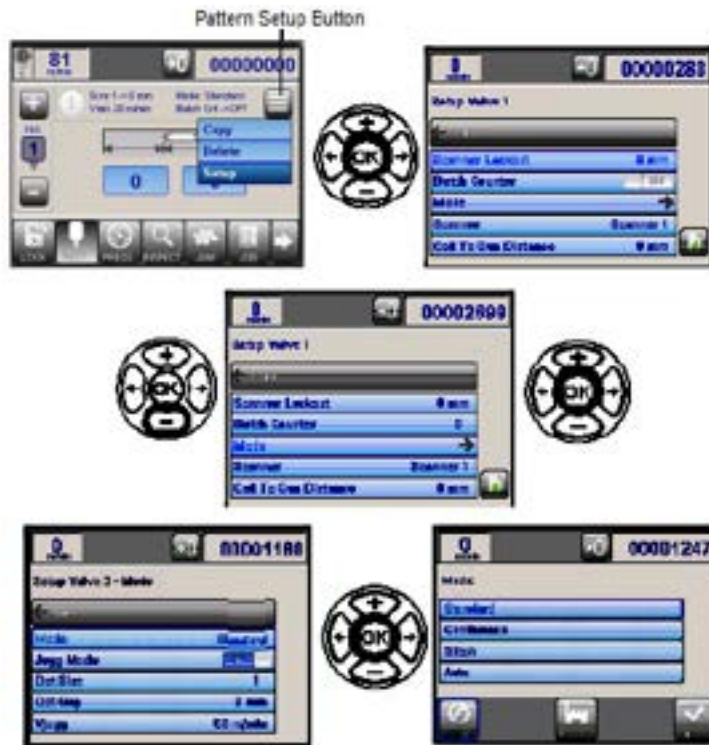

**Mode** - The gluing style. Use the Left/Right arrows to scroll to the Pattern Setup Button, and then click on “OK.”

Use the Plus/Minus Buttons to scroll through the choices to “Mode” and then click on “OK.”

Mode choices include:

**Standard** - This is also called “pattern-skip-pattern” mode, “pattern mode” or “normal mode.”

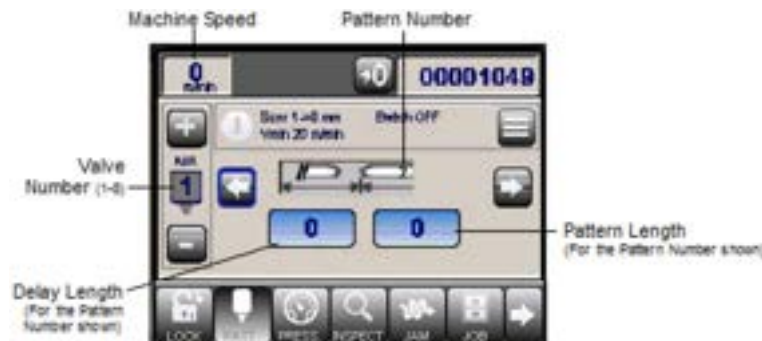

## Set the Pattern Menu Information - Continued

Stitch Mode is very similar to Standard Mode, with the exception that the glue “patterns” are applied in a stitchlike arrangement of smaller beads and gaps. The beads and gaps are entered in units of length.

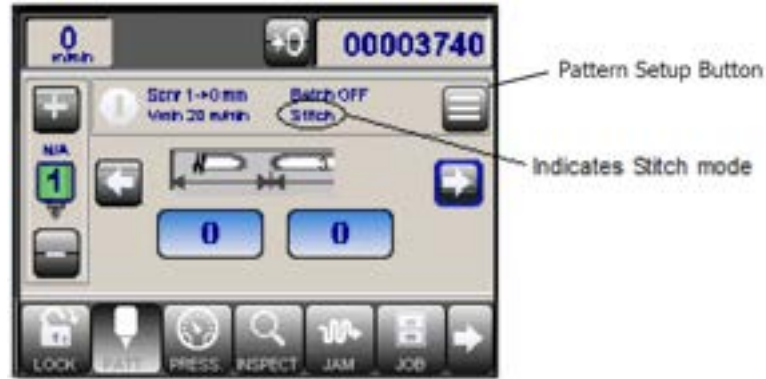

1. To change a bead or gap length, press the Pattern Setup button. Select “Mode.” The Mode Menu opens.



2. Select “Stitch Length” (bead) or “Stitch Gap” to edit that value. A thumbwheel sub-menu opens.



3. After changing the value, select “Apply” to set the changes.

**Continuous** - Applies adhesive continuously when speed is higher than the Vmin setting.

**Auto** - Applies a strip of adhesive based on the length of the scanner signal. Input the start delay (length from the leading edge of the product to the beginning of the glue line) and the end delay (the end of the glue line to the trailing edge of the product).



Set the Pattern Menu Information - Continued

**Scanner Lockout** - Enter a product length to act as a scanner lockout when holes, writing, or other items produce a false trigger by the scanner.

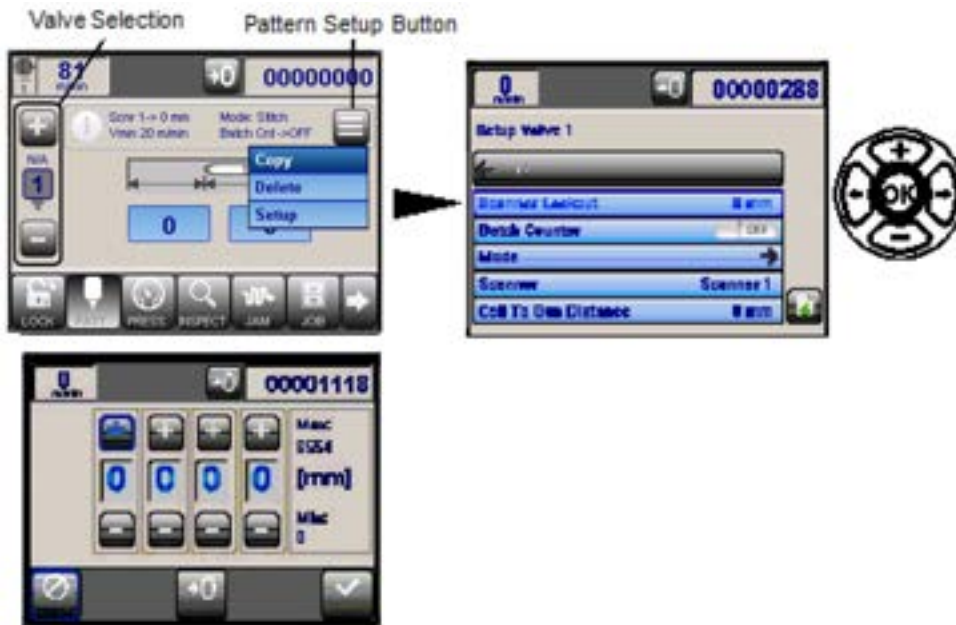

**Batch Counter:**

Batch counting is often used on a machine with manual packers. This option allows a kicker or marking valve to identify a group of products needing to be packed into a box.

**Batch Counter-On/Off** - Turn the batch counter on and off with the “switch” using the Plus/Minus Buttons.

**Batch Counter-Skip** - The total number of products for which the pattern will be skipped (no adhesive will be applied).

**Batch Counter-Glue** - The total number of products the adhesive pattern will be applied to, one after the other without skipping any products.

 The Batch Counter must be enabled under the Setup Menu.

**Scanner** - Select a scanner from the scroll list, using the plus and minus keys to highlight, press the Left or Right arrow to highlight “Apply,” and then press OK.

**Cell to Gun Distance** - Measurement - The distance between the valve (gun; shown on the left of the screen) to the scanner (cell) number, shown in the upper right corner. This value must be entered accurately to achieve proper pattern placement.

Set the Pattern Menu Information - Continued

**Jog Mode** - The Jog Mode Parameter is only available when Jog Mode is enabled.

When jog mode is enabled, and the machine speed is below 'Jogg Speed,' the pattern will be divided into a series of dots and gaps. When the machine speed increases beyond Jogg Speed, the pattern will return to a unified bead. Jog mode is used to prevent applying excessive adhesive at slow machine speeds, as well as to help clear a dried nozzle.

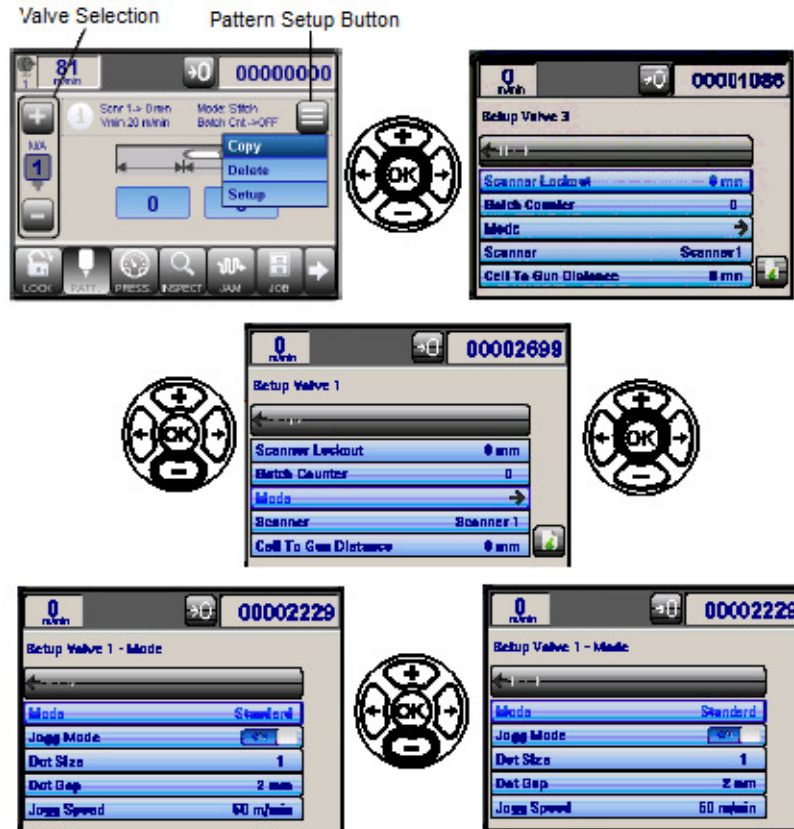

**Jog Mode - On/Off** - Turn the jog mode on and off with the “switch” by clicking on the “OK” button.

**Dot Size** - The size of the adhesive dots, from 1 (smallest) to 9 (largest).

**Dot Gap** - This is the distance between the glue dots while the machine is running below the jogging speed threshold. Increase the distance to decrease the glue volume.

**Jogg Speed** - Controls the speed at which the pattern will transition from dots to a unified line, in m/min.

Set the Pattern Menu Information - Continued

**SETUP EXAMPLE:** The following is an example of setting up a pattern gluing mode (Standard) with three patterns for valve one:

1. Set the Delay Length for pattern 1. The Delay Length for pattern 1 is the measurement from the first edge of the product to where you want the first glue line to start.



2. Press the Right Arrow Button to view the Pattern Length for pattern 1. The Pattern Length is the length of the glue line (for the pattern number indicated). Press the OK Button to view the thumbwheel, and use the Plus/Minus Buttons to change. Press the right arrow button until "Apply" is highlighted, and then press the OK Button to enter the setting.



3. Press the Right Arrow Button until the scroll right button is highlighted, and then press Okay to view the Delay Length for pattern 2. The control automatically fills in the Delay Length for pattern 2 (so the next pattern does not interfere with the previous pattern). This number can be adjusted if desired.

Set the Pattern Menu Information - Continued

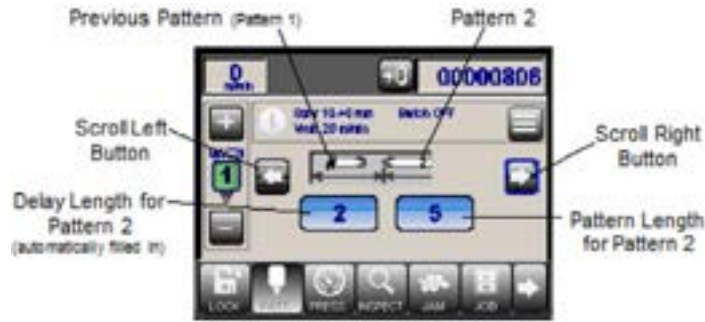

4. Press the Right Arrow Button until the scroll right button is highlighted, and then press OK to view the Pattern Length for pattern 2. Press the OK Button to view the thumbwheel, and use the Plus/Minus Buttons to change. Press the Right Arrow Button to highlight "Apply," and then press OK to enter the setting.
5. Repeat the above procedure to set pattern 3.

All three patterns are now set. You may review them using the left and right scroll buttons.

The Pattern Glue Mode for Valve 1 is now ready.

## Set the Pressures

The Pressure Button is used to enter/change the Electronic Pressure Control (EPC) parameter values. The EPC matches the fluid pressure to the machine speed, achieving consistent pattern volume. As machine speed increases, the valve remains open for a short period of time. For the same volume of adhesive to appear on the product, the adhesive must flow at a higher rate, achieved by increasing the fluid pressure.

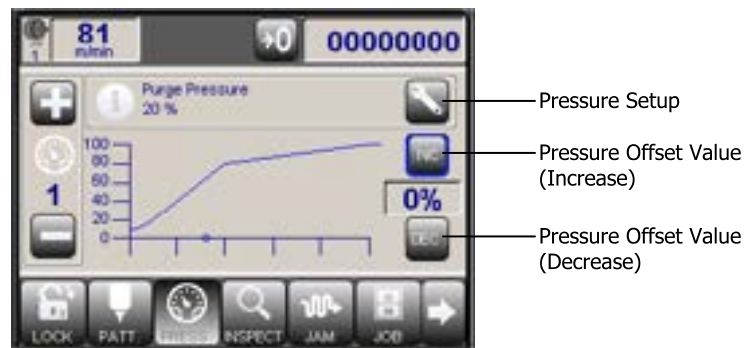

**Pressure Offset Value** - Used to increase/decrease the current pressure. The Pressure Offset is used to do minor pressure adjustments instantly. It does not change the pressure table profile.

*Highlight the Pressure Setup Button, and then press OK, to access the Pressure Setup screen. This screen allows scrolling (plus and minus keys) through a set of pressure setup menu keys.*

Set the Pressures - Continued



**Purge Pressure** - The pressure setting when the machine is at zero speed.

**Speed 1** - Speed (m/min) for pressure point 1.

**Pressure1** - Pressure setting at point 1 in the pressure curve (%).

**Speed 2** - Speed (m/min) for pressure point 2.

**Pressure 2** - Pressure setting at point 2 in the pressure curve (%).

**Speed 3** - Speed (m/min) for pressure point 3.

**Pressure3** - Pressure setting at point 3 in the pressure curve (%).

**Speed 4** - Speed (m/min) for pressure point 4.

**Pressure 4** - Pressure setting at point 4 in the pressure curve (%).

**Encoder** - Select encoder number.

 The number of pressure points on the pressure curve are input during setup.

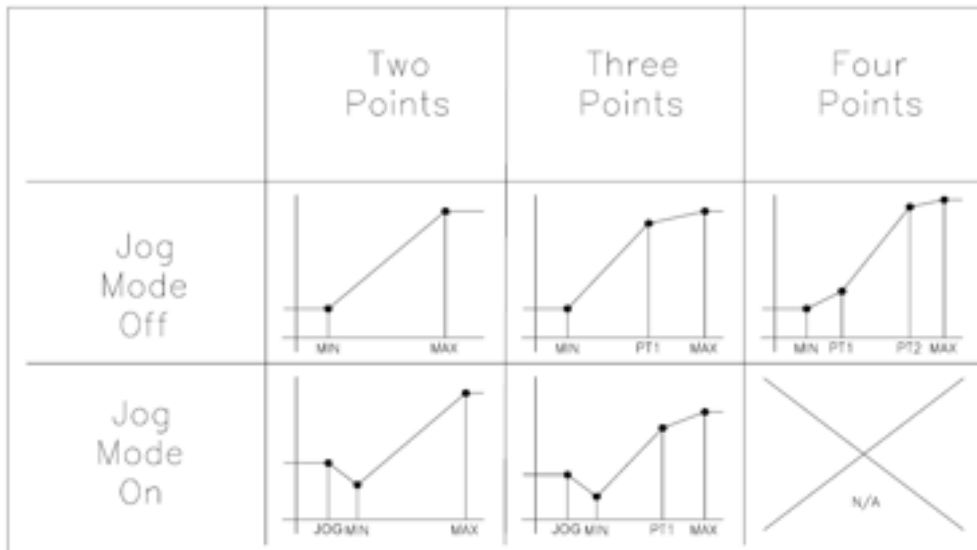

The graph above illustrates two, three, and four points on the pressure curve with Jog Mode off and on. The majority of projects will be fine with the Jog Mode off and only two points on the pressure curve. If more control is necessary, try adjusting the number of points on the pressure curve.

---

## Purge and Test Run

---

1. Purge all air from the glue line, and then connect to the valve. Purge the valve by activating the push button switch on the valve.

 Scanner and valve cables must be connected before any purging can take place. Be certain all cables and lines are connected.

2. Run adhesive through the valve(s) until no air is present in the line.
3. Run the parent machine and stop it when the product reaches the glue station.
4. Adjust the glue station vertically to ensure the product is level.
5. Slowly jog the product through the glue station making any needed adjustments to the glue station guides and brackets as you go.
6. Start up the parent machine and run 2-4 products through the glue station.
7. Measure the glue line with a tape measure. Make sure the glue line is in the correct place on the products tested.

 If the glue is not in the proper place on the products, review and adjust the pattern settings. See Set the Pattern Menu Information, above.

8. If the glue is in the proper place on the products tested, you can run the machine at normal operating speed!

# Job Screen

Selecting the Job Button  opens the Job Screen (not accessible at all levels).

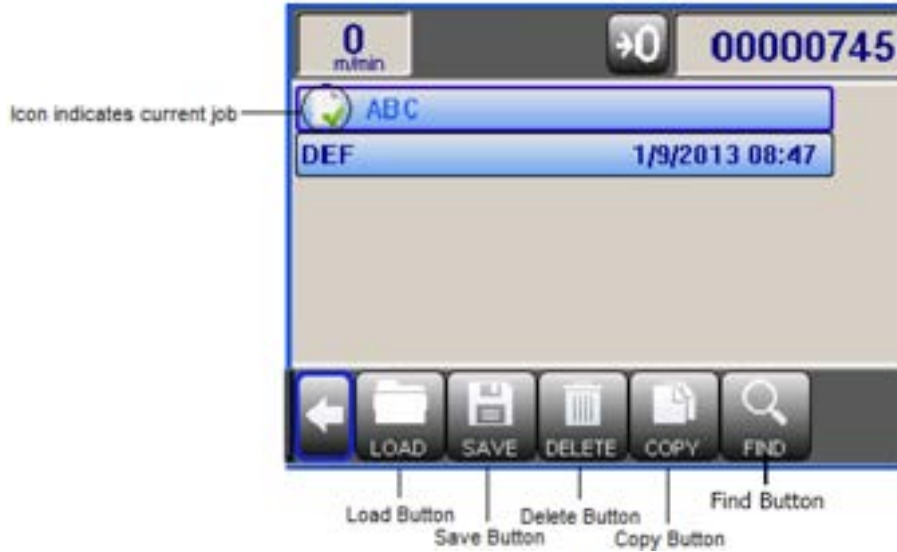

**Job Screen**

## Loading a Job

To load a job:

1. Select the job you wish to load from the list.
2. Select the Load Button.

 A prompt will appear. If you wish to save any changes to the current job, select “Yes.”



 Selecting “No” opens a keyboard, allowing the current job, with any changes, to be saved as a new job name (alphabetic or numerical). Enter the new job name and select “Save.”

*Loading a Job - Continued***Saving a Job**

To save the current job:

1. Select the Save Button.

 A prompt will appear. Select “Yes” to overwrite the current job with the new changes. For a “save as” option, select “No” to open the keypad described in “Loading a Job.”

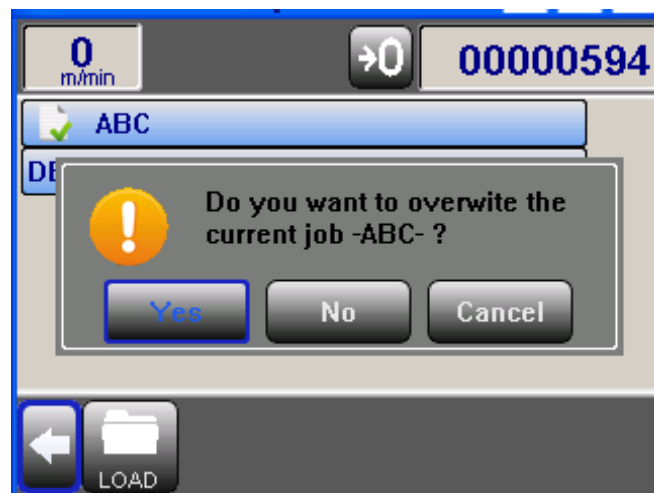



### Deleting a Job

To delete a job:

1. Select the job you wish to delete from the list.

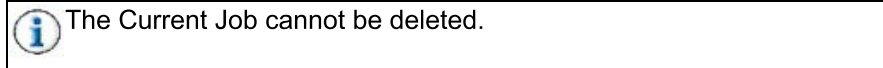

2. Select the Delete Button.

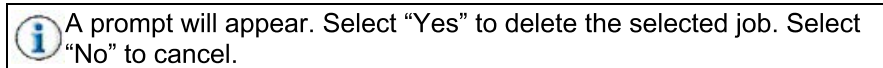

### Copying a Job

To copy a job:

1. From the list, select the job you wish to copy.
2. Select the Copy Button.

A keyboard will open, to assign a new job name (alphabetic or numerical) to the copied job. Once saved, the new (copied) job appears on the list.



## Archive Screen



Selecting the Archive Button (not accessible at all levels) opens the Archive Screen.



### Archive Screen

#### Restore:

Restores selected backup to its previously-saved version.

#### Backup:

Creates a new backup (keyboard appears to enter new name).

#### Delete:

Deletes selected backup from the list.

#### Re-Init:

Re-initializes all settings.

 The Default configuration is locked and cannot be rewritten or deleted.

# Service Screen

Selecting the Service Button  opens the Service Screen.



**Service Screen**

The Service Screen keeps an update on service intervals.

When a service period/count is down to 20% from the 'deadline,' the green LED icon for that item turns yellow.

When it is down to 10%, the icon turns red.

When a deadline is reached without service being performed, the screen indicates "Service Now,"

Beyond the deadline, the screen indicates "Overdue."

Selecting an item from the service list opens a prompt:



If scheduled service has been performed, select "Yes" to reset the service period/count.

# Inspection Screen

## Overview

The Inspection screen displays and maintains the results from the sensor channel's inspection process and analysis. This screen allows access to the results and settings for sensor channels 1 to 3. There are three main sensor categories currently supported: analog sensors, digital sensors, and barcode sensors. The screen's appearance will change for each category.

### Analog Sensor View



### Digital Sensor View









### Barcode Sensor View



---

**Function Bar Buttons**

---

	<b>Back Button</b>	Returns the function bar to allow access to other main menus.
	<b>Stat Button</b>	Displays the Statistic screen.
	<b>History Button</b>	Displays the History Message Screen.
	<b>Inspection Diagnostic Button</b>	Displays the Inspection Diagnostic Screen.
	<b>Learn Button</b>	Initiates the learn process.
	<b>Volume Button</b>	Controls Volume Inspection for Analog sensors, and learn types
	<b>Learn Reference Button</b>	Initiates thr unglued sample learning process.

---

**Inspection Status Icon**

---

The Inspection status icon can display three different states to alert the user to the current inspection state:



**Unknown State** – The encoder speed is below the v/min setting for the inspection S channel.



**Error State** – Displays for a failed learn or inspection.

For a failed inspection (based on the sensor type), the system failed its pattern inspection, volume inspection, barcode inspection and length inspection.



**Good State** – Displays for a successful learn or inspection.

For a successful inspection (based on the sensor type), the system passed its pattern inspection, volume inspection, barcode inspection and length inspection.

---

## Inspection Status Information Bar

---

The Inspection Status Information Bar has three levels that can be changed by pressing the info icon .

**Level 1:**

For Analog & Digital Sensors:



Displayed Information includes:

Channel Scanner Number and the distance to the sensor.

Marking valve distance to the sensor.

The Sensor Channel Reference mode.

For Barcode Sensors:

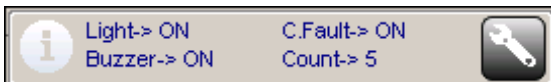

Instead of displaying the reference mode, the Barcode acquisition mode is shown.

**Level 2:**

Displayed Information Includes:

Channel Alarm Light Activation Status.

Channel Buzzer Activation Status.

Channel Consecutive Fault Activation Status.

If Consecutive Fault Activation Status is enabled, the count will be show as well.

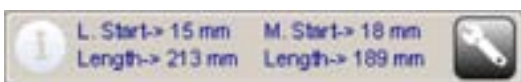
**Level 3:**

Displayed Information Includes:

On the left, the learned start and length of the current pattern is displayed.

On the right, the measured start and length of the current pattern is displayed.

 The data displayed is relative to the current pattern displayed, and is updated when using the Previous/Next Pattern Buttons (if available for the current products inspection).

### Inspection Pattern Graphic

The Inspection Pattern Graphic updates on every product. There are seven different pattern states possible, shown via this graphic.

 The graphic update may not be seen for failures at high speeds, unless there are multiple errors in a row.

**Graphic Info:** The graphic contains much useful information to the inspection process and analysis.



**Pattern Graphic Possible States:**

**Good Pattern** - The Current Pattern matches the Target/Learned Pattern data. The Pattern will align between the two tolerance box center lines.

 The pattern color remains green as long as it is within learned pattern data tolerance.

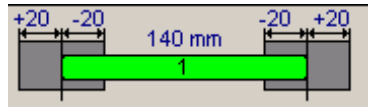

**Missing Pattern** - The Inspection analysis could not find the learned target pattern.



**Extra Pattern** - The Inspection analysis found a pattern where it did not expect one.

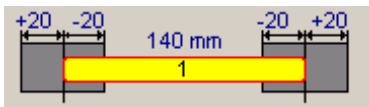

**Early Start** - The Inspection analysis found the pattern started too early, and was outside allowed tolerance.

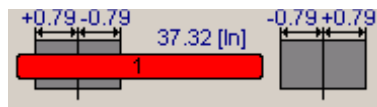

**Late Start** - The Inspection analysis found the pattern started too late, and was outside allowed tolerance.

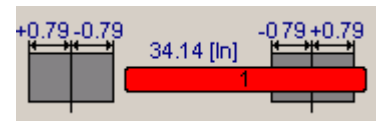

Inspection Pattern Graphic - Continued

**Early End** - The Inspection analysis found the pattern ended too early, and was outside allowed tolerance.

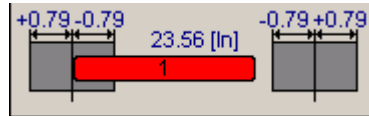

**Late End** - The Inspection analysis found the pattern ended too late, and was outside allowed tolerance.

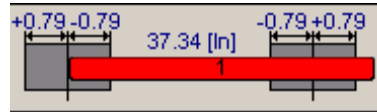

**i** It is possible for pattern start and end errors to overlap.  
 For example: The image below would report both a Late Start and Late End error.

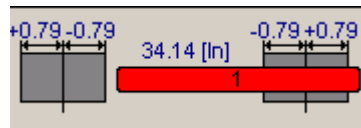

**Inspection Pattern Buttons**

The Inspection Previous and Next Pattern buttons will display if there is more than one pattern involved with the inspection analysis. The buttons will also turn red to indicate there was an error on a different pattern.

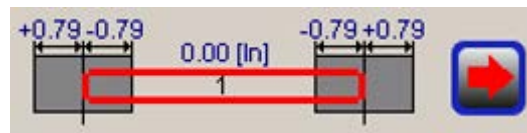

**Inspection Volume Bar**

The Inspection Volume Bar is only available for analog sensors that inspect product volume. The volume bar display is controlled by the volume button, in the function bar at the bottom of the screen. The volume bar is shown when volume inspection is enabled. The volume bar is hidden when volume inspection is disabled.

The red area, on the left, identifies volume below the lower threshold.

The red area, on the right, identifies volume above the upper threshold.

The green area identifies volume between the upper and lower thresholds.

The black line indicates the current volume amount.

If the current volume is below the lower threshold, the product fails the inspection with volume inspection enabled, and volume insufficient error messages will appear. If the current volume is above the upper threshold, the product fails the inspection with volume inspection enabled, and volume excess error messages will appear.

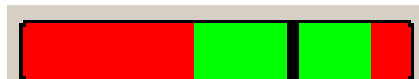



### Inspection Learn Process

The inspection learn process is started by pressing the learn button  on the function bar, at the bottom of the screen. A learn can be performed for one or multiple sensor channels.

#### Single Sensor Channel Learning

Pressing the learn button with only one sensor active will display a wait prompt, instructing the operator to run the number of products specified by the learn count setting. It will also display a timeout timer.

 The Learn Count and Timeout settings can be changed under the Inspection System Settings Menu.



#### Multiple Sensor Channel Learning

Pressing the learn button with multiple active sensors will display the following prompt, instructing the operator to use the sensor activation buttons to:

- Select which sensor channels to perform a learn for and;
- Confirm the selection with the Okay button.

 The Sensor activation button LEDs will blink if the sensor channel is not selected for the learn. The LED will turn solid green if the sensor channel is selected for the learn.



If no sensors are selected, and the Okay button is pressed, the following message will display and the learn will cancel.



*Inspection Learn Process - Continued*

If sensors are selected, the learn will continue instructing the operator to run the number of products for the learn counter setting, and begin counting down from the set timeout.

**Sync Scanner Learning Feature**

If the Sync Scanner is enabled under the Inspection System Settings Menu, and a learn is started, the operator will be prompted to 'learn' the scanner distance from the sensor's scanner to the sync scanner.

Confirming Yes, will continue, instructing the operator to make sure there are no products on the line. After confirming that the line is clear, the learn timeout prompt will display.

**CAUTION!** The production line must be empty, or the scanner distances will 'learn' incorrectly.



---

## Learn Result Messages

---

There are four, different Learn Result Messages possible.

**Learn Aborted** – Displayed when the abort button is pressed on the timeout prompt.

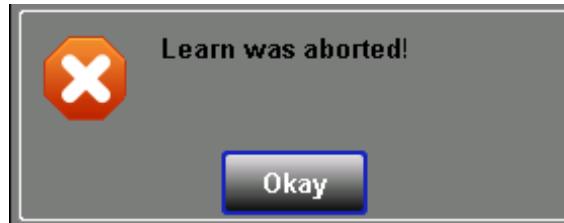

**Learn Timeout** – The learn count was not met by the time the timeout counter ran out.

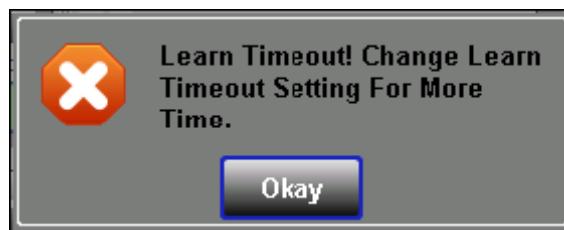

**Successful Learn** – Sensor(s) learned the product correctly.



**Learn Failure** - Prompt will show which sensor failed during the learn process.

 If a sensor was not selected for a 'learn,' it will not display as a failure.

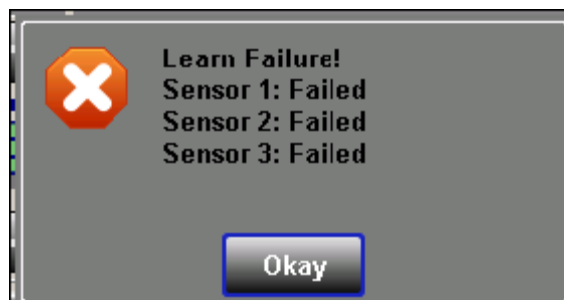

---

## Learn Types

---

### For Barcode Sensors:



Pressing the learn button will learn the products barcode.

### For Digital Sensors:

Pressing the 'Learn' button will learn the product's pattern or length (Sensor Dependent).



### For Analog Sensors:



Pressing the Learn button will learn the product's Glue Pattern and/or Volume.

If the 'Use Valve Parameters' setting is disabled, the inspection learn process will learn the product's pattern and volume.

If the 'Use Valve Parameters' setting is enabled, the inspection learn process will learn the product's volume only. Since the pattern dimensions from the Valve Channel will be used.

**Note: Linking the Valve Channel to the Inspection Channel is 1 to 1. Meaning Valve Channel 1 can only be linked to Inspection Channel 1, Valve Channel 2 to Inspection Channel 2, ect.**



Pressing the 'Ref' button will learn the product's unglued reference.

**Note: For learning the reference/unglued sample: If the Valve Channel is linked to the Sensor Channel, and the Valve activation is On, it will be disabled for the learn process and then re-enabled after the learn is completed.**

---

## Sensor Activation Status

---

The sensor activation status is displayed by the green LED on the sensor activation button, and on the screen with the sensor status icon.

*Sensor On/Enabled* will change the status icon to:



*Sensor Off/Disabled* will change the status icon to:



---

### ***Navigating to a Different Sensor Channel***

---

When more than one sensor is active, the Next/Previous sensor buttons can change from the current sensor to another.



---

### ***Supported Sensor Types***

---

Supported Analog Sensor: AS, CGS, and CGS-S

Digital Sensors

Barcode Readers

---

### ***Inspection Alarm/Error Features***

---

There are five different, supported alarm features, for each sensor channel, under the Sensor Inspection settings *Alarms* sub menu:

**Alarm Light** - When active and an error occurs, the blue alarm beacon will illuminate until the alarm mode condition is met.

**Alarm Buzzer** - When active and an error occurs, the buzzer alarm beacon will turn on until the alarm mode condition is met.

**Alarm Consecutive Faults** - When active and the fault count is met, the consecutive fault relay will activate until the alarm mode condition is met.

**Marking Valve/Kicker** - When active and an error occurs, the product will be marked or kicked accordingly.

**Ejector Relay** - When active and an error occurs, the product will be ejected from the product line.

Light, Buzzer, and Consecutive Faults alarms support three modes:

**Timer** - The alarm will be active until the set timeout is met.

**Next Good Product** - The alarm will remain active until the next good product.

**User Reset** - The alarm will remain active until the message banner at the top of the screen is cleared.

 The various alarm modes and timeout settings are under the "Inspection System Settings" -> "Alarms" menu.

### Inspection Reference Modes (only available for analog sensors)

There are four reference modes available for analog sensors:

**Manual** - will learn the reference value of the product, without glue, when learning an unglued reference.

**Continuous** - will learn the reference value of the product, continuously on each product, given that the learned target pattern data is accurate.

**Differential** - Will learn the profile of the unglued sample, and will later be used to mask out areas of the sensor signal.

Maximum

## Inspection Channel Settings

### Overview

The Inspection channel settings can be accessed by pressing the settings button in the Inspection Screen Information bar.

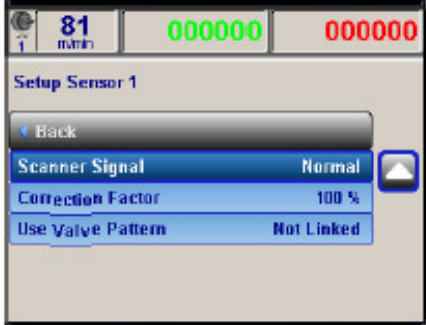
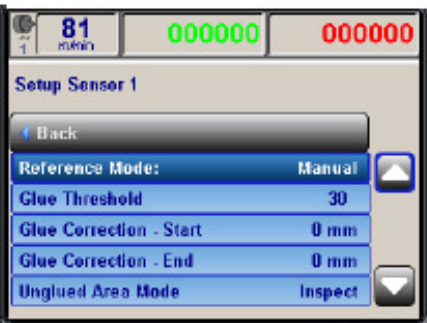

### Sub Menus

There are two sub menus for the Inspect Channel Settings Menu:

**Tolerances** - Contains the various tolerance settings for the inspection channel.



**Alarms** - Contains the various alarm-enables for the inspection channel.



## Inspection Diagnostic Screen

### Overview

The Inspection Diagnostic Screen is a sub screen, under the Inspection screen, that displays a line graph containing the sensor's data in real time.

Data relevant to the inspection process includes the threshold limits, the target pattern(s) start and stop, and the current pattern(s) start and stop. The graph X-Axis is in pulses, and the Y-Axis is the signal strength.



**Button Features**

The Inspection Diagnostic screen has six buttons on the function bar, located at the bottom of the screen, as well as a setting button in the status information bar at the top of the screen. The ZOOM and PAN buttons will be disabled when a zoom or pan has reached its limit.

 The Zoom and Pan buttons are only shown for analog sensors, and will not be displayed for digital or barcode sensors.

**Zoom In (+) & Zoom Out (-)**

There are four different zoom levels that change the Y-Axis-range limits.

**ZOOM 1:**



**ZOOM 2:**



**ZOOM 3:**



**ZOOM 4:**



**Pan Up & Pan Down**

With Zoom active, the Pan buttons are able to adjust the chart up or down, to move data in and out of the graphs view.

When the graphs max of 250 is shown, the Pan Up button will be disabled. When the graphs min of 0 is shown, the Pan Down button will be disabled.





### Alternative View Button

The Alternative view button can show the user different sets of sensor data, particularly the last Learned Product, and the last Last Error product. This is controlled by the Alt. View setting under the screen's settings menu. When the button is pressed, the icon will turn green and update the graph. When Alt. View is set to Learned Product, the graph might appear slightly different than the current sensor data for a Learned Product. When Alt. View is set to Last Error, the difference between the current data should be noticeable as to why the product failed.

 The Alt. View will show the selected, Learned Product or Last Error, sensor data for analog and digital sensors. For barcode sensors, it will enable the test mode.

Alt. View - Learned Product

Alt. View - Last Error



### Save Button

Pressing the save button will prompt the user to save the current product inspection data to a text file. Pressing Yes, will save the data. Pressing No, will cancel the save. If there is a USB inserted into the control, the file will be saved onto it. If there is no USB present, the file will be saved onto the controls SD card.



### Graph Features

Pressing down on the graph will display the graph, the tolerance data lines, pattern data lines and analysis screen lines.

 The volume tolerance and threshold lines are only displayed for analog sensors.

Before

After



---

## Graph Line Legend

---

Pressing on the *Info* icon  will display the graphs legend. Pressing it again, will hide the legend.



---

## Screen Info Bar Data

---

The Info bar near the top of the screen displays information relative to the sensor and the inspection process. The displayed information will be different, depending on sensor type.

### For Analog Sensors:

The sensor idle signal will be displayed. This is the minimum sensor data value, giving a basis for how the sensor is performing. A high idle signal may indicate a sensor issue.

The Inspection absolute glue level (GlueABS), displayed as the green horizontal line on the line graph, is the minimum glue level expected by the inspection process. A majority of the sensor data will be above this line.

The Inspection Upper Volume Tolerance Threshold (High-T) is the upper volume level for the current inspection. If the sensor data is above this line, the glue volume exceeds the target volume upper threshold.

The Inspection Lower Volume Tolerance Threshold (Low-T) is the lower volume level for the current inspection. If the sensor data is below this line, the glue volume is insufficient to the target volume lower threshold.



### For Digital Sensors:

No data will be displayed at this time.

### For Barcode Sensors:

The sensors-enabled symbology modes are displayed. This indicates what bar code types are enabled, to be read by the sensor.

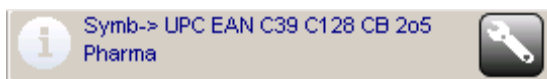

---

### Sensor Diagnostic Test Modes

---

There are two Diagnostic Test Modes. One is for Analog Sensors, and the other is for Barcode Sensors.

**For Analog Sensors:**

With the belts stopped, the Idle prompt in the information bar will switch to display Current.

Moving a product underneath the sensor, with the belts stopped, will display the current analog sensor signal at that time.



**For Barcode Sensors:**

Pressing the Alt. View button will put the sensor into test mode.

A percent bar and display prompts for the current percent and current code that was read.

The percent, ranging from 0 to 100, will indicate how well the barcode reader is identifying the current barcode

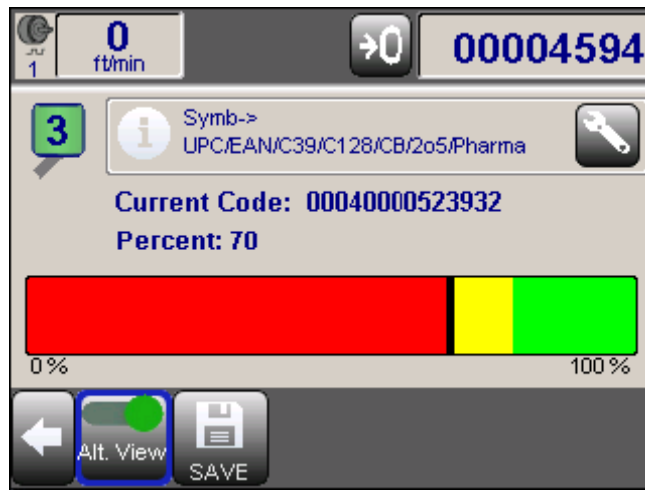

---

## Statistic Screen

---

### Overview

---

The Statistic screen is a sub menu, under the Inspection screen, that contains counter information relative to the inspection process and analysis. This screen details when the job started (controlled by the last time the statistics were cleared), the total job count, the total number of job failures, and the individual failure counters for each sensor.

### Totals Page

---

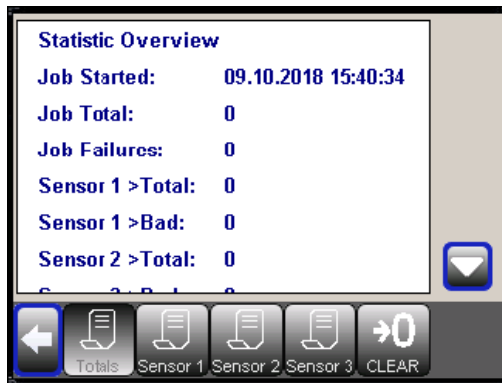

The Totals page contains:

- The time and date that the job was started, and which is set when the counters are cleared.

- The Job Total count, consisting of all totals for all active sensor channels.

- The Job Failure count, consisting of all failures for all active sensor channels.

- The Total count for each individual sensor channel.

- The Failure count for each individual sensor channel.

---

### Sensor Pages (X)

---

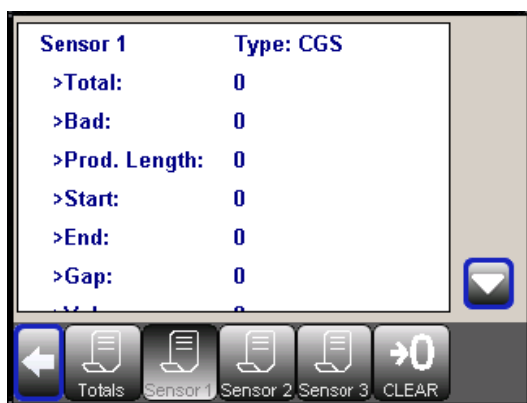

The Sensor (x) pages display the various counters used by that sensor channel. Each sensor type has a Total count, Last Error/Failure count, and a Product Length Failure count. The other counters can vary, based on the sensor type.

---

## Clearing of Sensor Statistics

---

Pressing the Clear button prompts the user to confirm the clearing of all statistics, which cannot be undone.



---

## Sensor Type Counters

---

Generic Sensor Counters:

Total:

Last Error:

Prod. Length: (Product Length was above or below its tolerance.)

 Product Length inspection must be enabled for this inspection counter to be active.

### Analog Sensor Counter Types (AS , CGS, CGS-S):

Start: (Pattern Start was above or below tolerance.)

End: (Pattern End was above or below tolerance.)

Gap: (Space between patterns was above or below tolerance.)

Volume: (Amount of glue detected was above or below tolerance.)

Extra: (An extra glue pattern was detected.)

Missing: (A glue pattern was detected as missing.)

### Digital Sensor Counter Types:

Start: (Pattern Start was above or below tolerance.)

End: (Pattern End was above or below tolerance.)

Gap: (Space between patterns was above or below tolerance.)

Extra: (An extra glue pattern was detected.)

Missing: (A glue pattern was detected as missing.)

### Skew:

Barcode Sensor Counter Types:

Bar Code: (Product Bar Code was not detected.)

---

## Screen Navigation

---

The selection button for the current page is disabled, and enabled again after switching to a different page.

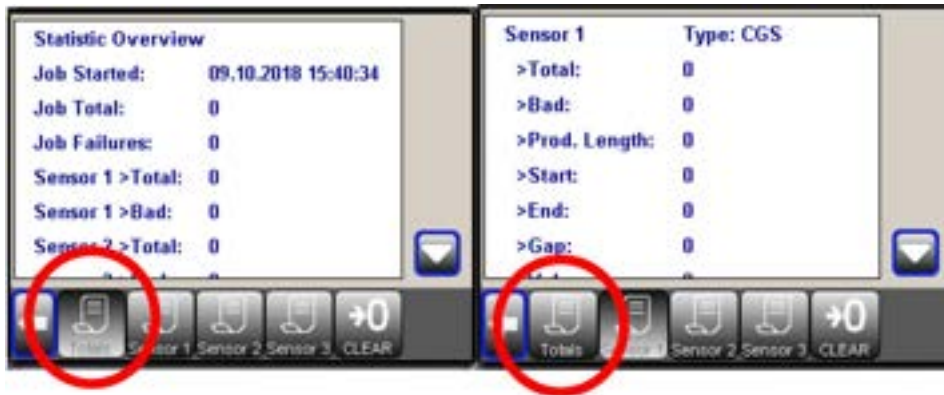

Page Up & Page Down Buttons are shown automatically, based on the required number of counters.



---

# History Screen Notes

---

## Overview

---

The History screen is a sub menu, under the Inspection screen, showing all error messages from the inspection process and analysis. This screen details each error type, and offers information on why the error occurred.



---

## Show Info. Button

---

Selecting an error message from the list, and pressing the *Info.* button, displays a prompt detailing the message type, the sensor channel it originated from, the time and date the error was logged, the error type, and additional information based on the error type.



---

## Delete Button

---

Selecting a highlighted history entry and pressing the Delete button will prompt the user to confirm deletion, and then remove it from the list. Clicking Yes on the prompt will open a wait screen, and the entry will be removed from the list once it is deleted from the event history.



*Delete Button - Continued*

A Multi-Select delete option is available by clicking on an entry twice, turning the selection circular selection icon dark gray.

Pressing the Delete button will display the same prompt as for a single entry, and then remove the selected items from the event history.

**Sensor Filter Buttons**

Depending on how many sensor channels are enabled, the filter buttons could range from 1 to 3.

When the button shows the green filter icon, the history messages are shown in the list.

Example: Pressing the filter button for sensor 1 will change the icon to grey and then remove all of the sensor 1 messages from the list.

Re-enabling it will allow the messages from sensor 1 to be placed back in the list.

**Page Buttons**

The Event History is currently capped at 35 entries, and the oldest entry is then replaced upon the arrival of a new entry. The Up & Down page buttons will display if there are more entries to be shown. The Down button will navigate to older messages, and then the Up button will appear, allowing the user to go back to the newest message.





**Message Icons**

There are three different message icons that can appear. While an Error Message is probably the most common message that you will receive.

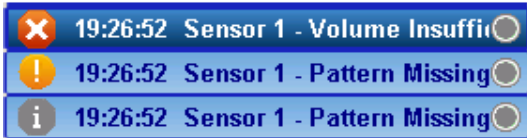

Error Message

Warning Message

Info. Message

**Additional Message Info.**

There are a few special message error types that display extra information.



Message Types and Information shown	
Volume Excess	Indicates the product glue volume was over the target threshold.
Additional information includes	Upper threshold amount value, and the current, measured product volume value.
Volume Insufficient	Indicates the product glue volume was under the target threshold.
Additional information includes	Lower threshold amount value, and the current, measured product volume value.
Product Length Long	
Product Length Short	Product Length is out of target tolerance.
Additional information includes	The amount, in inches or millimeters, by which the product length was off.
Pattern Early Start	
Pattern Late Start	
Pattern Early End	
Pattern Late End	

*Additional Message Info.- Continued*

Additional information includes	The pattern number and amount, in inches or millimeters, by which the pattern length was off.
Missing Pattern	
Extra Pattern	
Additional information includes	The extra or missing pattern number.
Gap Fault	
Additional information includes	The pattern number the gap belongs to, and the length by which the gap was off.

## Inspection System Settings Menu

### Accessibility

The Inspection System Settings Menu can be accessed at two places:

1. By pressing the Setup button on the function bar, when the inspection menu is displayed.



2. Under the regular System Settings Menu.



### Sub Menu Screens

There are three sub menu screens for the Inspection Setup Menu:

#### Inspection Marking Valve Settings Sub Menu.

Menu contains the settings for the valve type, Marking Valve Pattern Modes, Encoder Option, and distance to the reference scanner.

**i** The Delay Mode and Length Mode settings have a manual and an auto option. When Auto Mode is selected, the pattern data defaults to the pattern for the first active valve. When Manual Mode is selected, the pattern data is set using the Delay and Length setting options.



#### Inspection Reject Relay Settings Sub Menu.

Menu contains the enable for the Reject Ejector Relay, the length duration that it should stay active, and the distance to the reference scanner/photoeye.

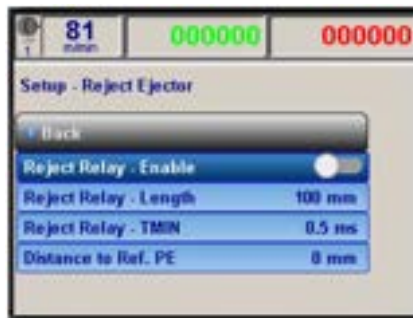

#### Inspection Alarm Settings Sub Menu.

Menu contains the mode settings for the Inspection Alarm Light, Alarm Buzzer and Consecutive Fault Relay. If the Alarm Mode is set to timer, the timer setting will be shown.



---

***Inspection System Settings Menu - Settings***

---

**Learn Counter Setting** – Controls the number of products on which a 'learn' is performed.

 This is only relative to learning the unglued reference or volume.

**Learn Timeout Setting** – Controls the timeout period for the learn counter prompt.

**Sync Scanner Enable Setting** – Controls activation and use of the sync scanner.

---

## Section 6 - Maintenance

---

This section contains maintenance procedures for the Valco MCP-8I Control. A regular maintenance program helps ensure longer life and efficient operation of your system. A few minutes spent on maintenance greatly reduces downtime.

---

### Purging the Adhesive

---

The system should be purged of air at every startup or shift change. To purge the system, follow these steps:

1. Install the applicator head onto the contact glue valve.
2. Purge adhesive until no air is present and the glue flows evenly.

 The glue valves can be purged manually using an activator located on the valve itself, by a solenoid-operated air valve, or they can be purged using the touchscreen panel and control.

When using any valve in the top-down position for the first time, it might be necessary to remove the valve and hold it so that the applicator head is at the top. The fluid pressure should then be set to 4 bar, and the solenoid should be fired until all the air is out and a flow of glue is present.

---

### Performing Downtime Maintenance

---

The type of downtime maintenance that is necessary for the MCP-8I Control Unit depends on the length of time the unit is down.

During short periods of downtime, such as order changeover, follow these steps:

1. Apply lithium grease or petroleum jelly to the orifice of the applicator head (contact extrusion valve) to prevent dried adhesive from clogging the valve.
2. Wipe the valve clean before restarting production.

For longer periods of downtime, follow these steps:

1. Remove the applicator head from the contact glue valve.
2. Install a stopper onto the contact glue valve in place of the applicator head.
3. Flush the applicator head with clean water.

If the system is idle for 30 days or longer, follow these steps:

1. Flush the entire glue supply system (including the pump or tank) with clean water (see Flushing the Glue System in this section).

---

## Flushing the Glue System

---

 Follow the procedures for your system. These are general guidelines only.

A mild vinegar-and-water solution (1 part vinegar, 10 parts water) should be used to flush the system. Water alone can be used when you are simply changing adhesives or preparing the system for an extended period of downtime.

The entire system must be flushed when the following conditions apply:

- A new adhesive formula is not compatible with the present formula. (Always consult your adhesive supplier regarding compatibility between adhesive formulas.)
- System shutdown exceeds 30 days.
- Glue-line buildup causes an excessive pressure drop.
- Excessive filter screen maintenance is required due to contaminated adhesive.

---

## Lubricating the System

---

To lubricate the system, follow these steps:

1. Use lithium grease on all machined threads and fittings when servicing the system.
2. Grease quick-disconnect fittings frequently to prevent dried glue from causing excessive wear.

# Section 7 - Specifications

Item	MCP-8I Unit
<b>Control dimensions:</b>	Height: 9.95 (252.7 mm) Depth: 7.81 (198.3 mm) Width: 13.95 (354.2 mm)
<b>Input voltage:</b>	100-240 VAC, 50-60 Hz (auto-selectable)
<b>Number of channels:</b>	8-channel operation with up to 8 programmable patterns per channel
<b>Glue pattern resolution:</b>	0.01 in. or 1 mm
<b>Number of scanner inputs:</b>	Up to 8 with scanner lockout
<b>Glue pattern tolerance:</b>	Less than 1 mm (.04 inches) at 610 m/min (2000 ft/min)
<b>Job storage memory:</b>	Up to 1000 jobs
<b>Miscellaneous:</b>	<ul style="list-style-type: none"> <li>Dual-encoder-based or timer mode</li> <li>Multi-valve, complex glue pattern capabilities</li> <li>“Continuous,” “Stitch” pattern and “Jogg” gluing</li> <li>Adjustable minimum speed</li> <li>Inch or metric calibration</li> <li>CE compliant</li> <li>Password protection for key system parameters</li> <li>Integral fluid-flow control option (EPC) and external EPC output</li> <li>Web break detection option</li> <li>Batch count/production count</li> <li>Programmable valve output voltages depending upon base unit</li> <li>Jam Preventer w/Alarm and relay output</li> </ul>

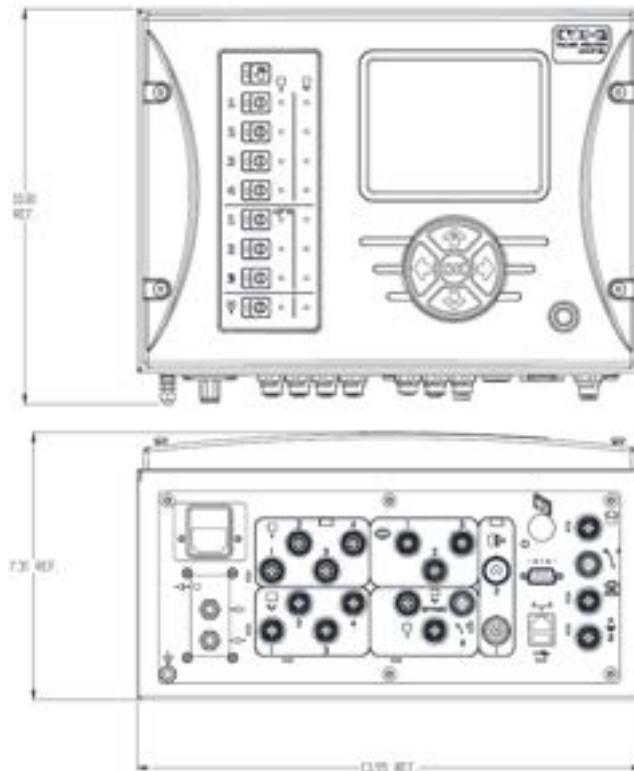





---

## Section 8 - Part Number List

---

### How to Order Parts

---

To order parts, please contact your closest Valco office by mail, phone, or Email:

#### **USA**

Valco Cincinnati, Inc.  
497 Circle Freeway Drive  
Suite 490  
Cincinnati, OH 45246  
Tel: (513) 874-6550  
Fax: (513) 874-3612  
Email: [sales@valcomelton.com](mailto:sales@valcomelton.com)  
Web: <http://www.valcocincinnatiinc.com>

#### **England**

Valco Cincinnati Limited  
Hortonwood 32  
Telford, TFI 7YN, England  
Tel: (+44) 1952-677911  
Fax: (+44) 1952-677945  
Email: [sales@valco.co.uk](mailto:sales@valco.co.uk)  
Web: <http://www.valco.co.uk>

#### **Germany**

Valco Cincinnati GmbH  
Bonnerstrasse 349  
40589 Dusseldorf-Benrath, Germany  
Tel: +49 211 984 798-0  
Fax: +49 211 984 798-20

#### **Spain**

Melton S.L.U.  
Pol. Industrial Agustinos  
calle G, n. 34  
31160 Orcoyen, Navarra, Spain  
Tel: (34) 948-321-580  
Fax: (34) 948-326-584

#### **France**

Valco Melton France  
Technoparc des Hautes Faventines  
32 Rue Jean Bertin  
26000 Valence  
Tel: +33 (0)4 75 78 13 73  
Fax: +33 (0)4 75 55 74 20

---

## MCP-8I Unit - Standard, Stand-alone (074XX101)

---

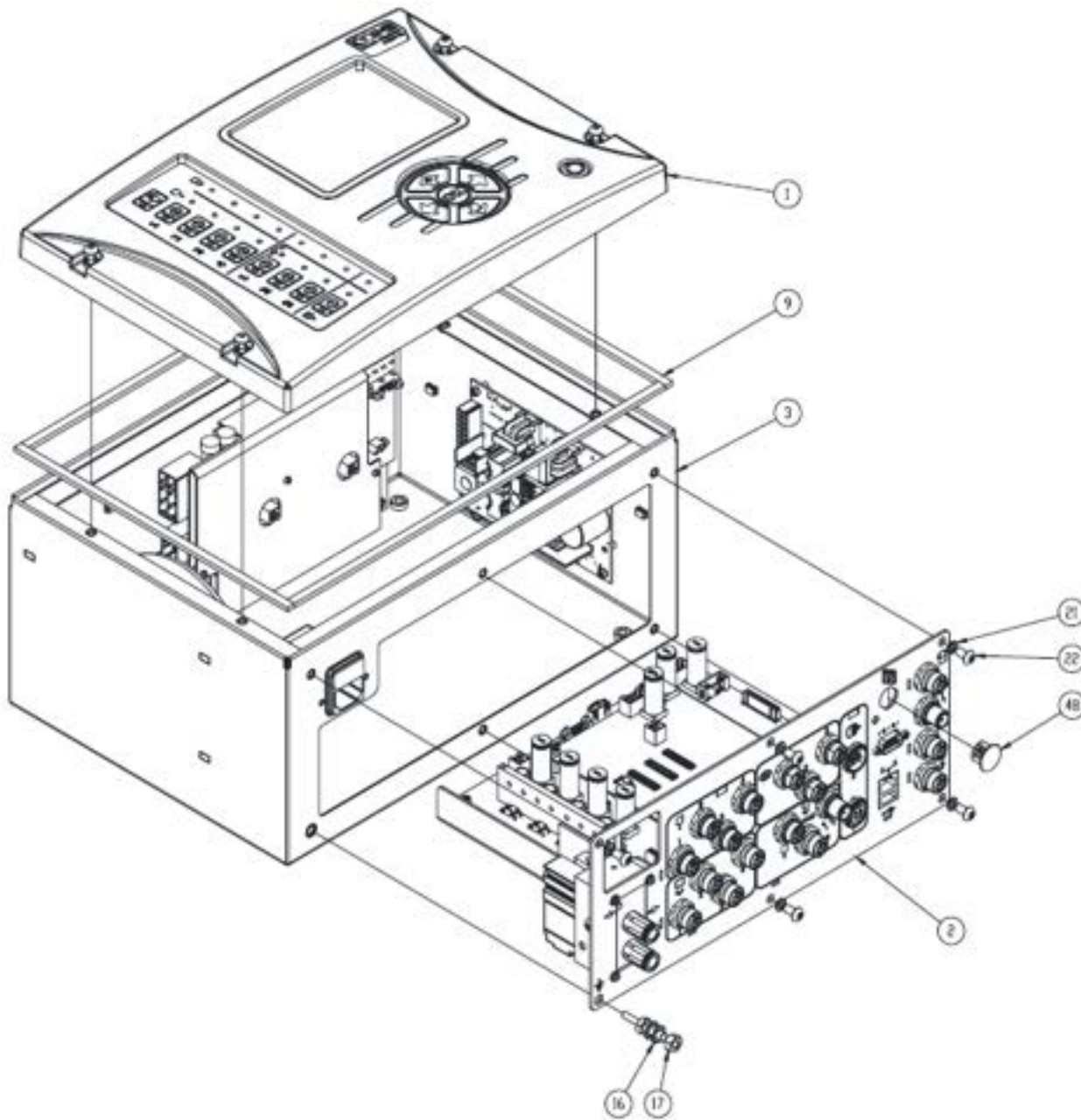

MCP-8I Unit (074XX101) - Continued

Item	Description	Part Number	QTY
1	COVER ASSY, MCP-8, INSPECTION	026XX458	1
2	RACK ASSY, PCB, MCP-8, INSPECT	074XX100	1
3	SHELL ASSY MCP-8	074XX091	1
9	GASKET; 1/8 THICK X 1/4 WIDE	746XX237	47
14	LABEL STOCK, SILVER	781XX780	1
16	LOCK WASHER M6 STL	784XX375	2
17	HEX NUT M6 ZINC	798XX301	1
21	SLW M5 ZINC	784XX475	5
22	BHCS M5 X 10 SS	784XX374	5
30	CABLE ASSY, 2P, 2P, JST, MCP8	029XX602	2
33	*CABLE ASSY,RIBBON,10 PIN 2MM	033XX160	1
36	INSTALLATION KIT ASSY, MCP-8I	091XX796	1
37	*CABLE ASSY,HSD,4P,CODE-Z,0.5	029XX740	1
39	SLW M4 ZINC	798XX382	2
41	CABLE ASSY, SIGNAL STAND-BY	030XX791	1
47	ILLUSTRATION DRAWING	998IS863	1
48	*HOLE PLUG, DBL D, .625	781XX228	1

---

***MCP-8I Unit - Standard, Stand-alone, for Tri-Valve BoardRunner (JTS0134)***

---

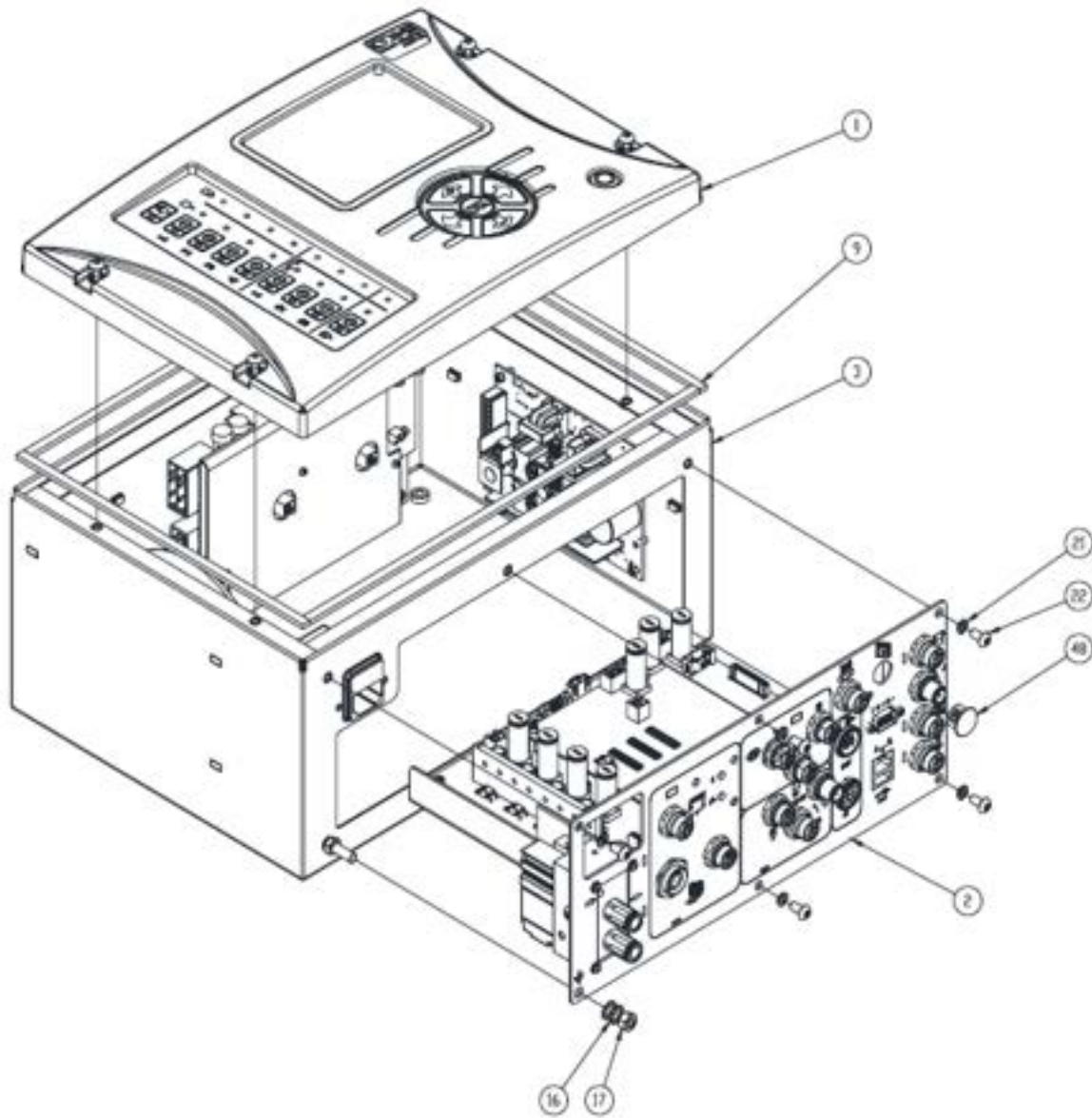

*MCP-8I Unit - Standard, Stand-alone, for Tri-Valve BoardRunner (JTS0134) - Continued*

Item	Description	Part Number	QTY
1	COVER ASSY, MCP-8, INSPECTION	JTS0100	1
2	RACK ASSY, PCB, MCP-8I,TIPSEAL	JTS0133	1
3	SHELL ASSY MCP-8	074XX091	1
9	GASKET	746XX237	47
14	LABEL STOCK, SILVER	781XX780	1
16	LOCK WASHER	784XX375	2
17	HEX NUT	798XX301	1
21	SCREW	784XX475	5
22	SCREW	784XX374	2
30	CABLE ASSY.	029XX602	1
33	CABLE ASSY.	033XX160	1
36	INSTALL KIT, ELEC, MCP8	091XX687	1
37	CABLE ASSY.	029XX740	1
39	WASHER	798XX382	2
41	CABLE ASSY, SIGNAL STAND-BY	030XX791	1
47	ILLUSTRATION DRAWING	JTS0109	1
48	HOLE PLUG	781XX228	1

**MCP-8I Unit - Remote Base Assembly (JTS0105)**

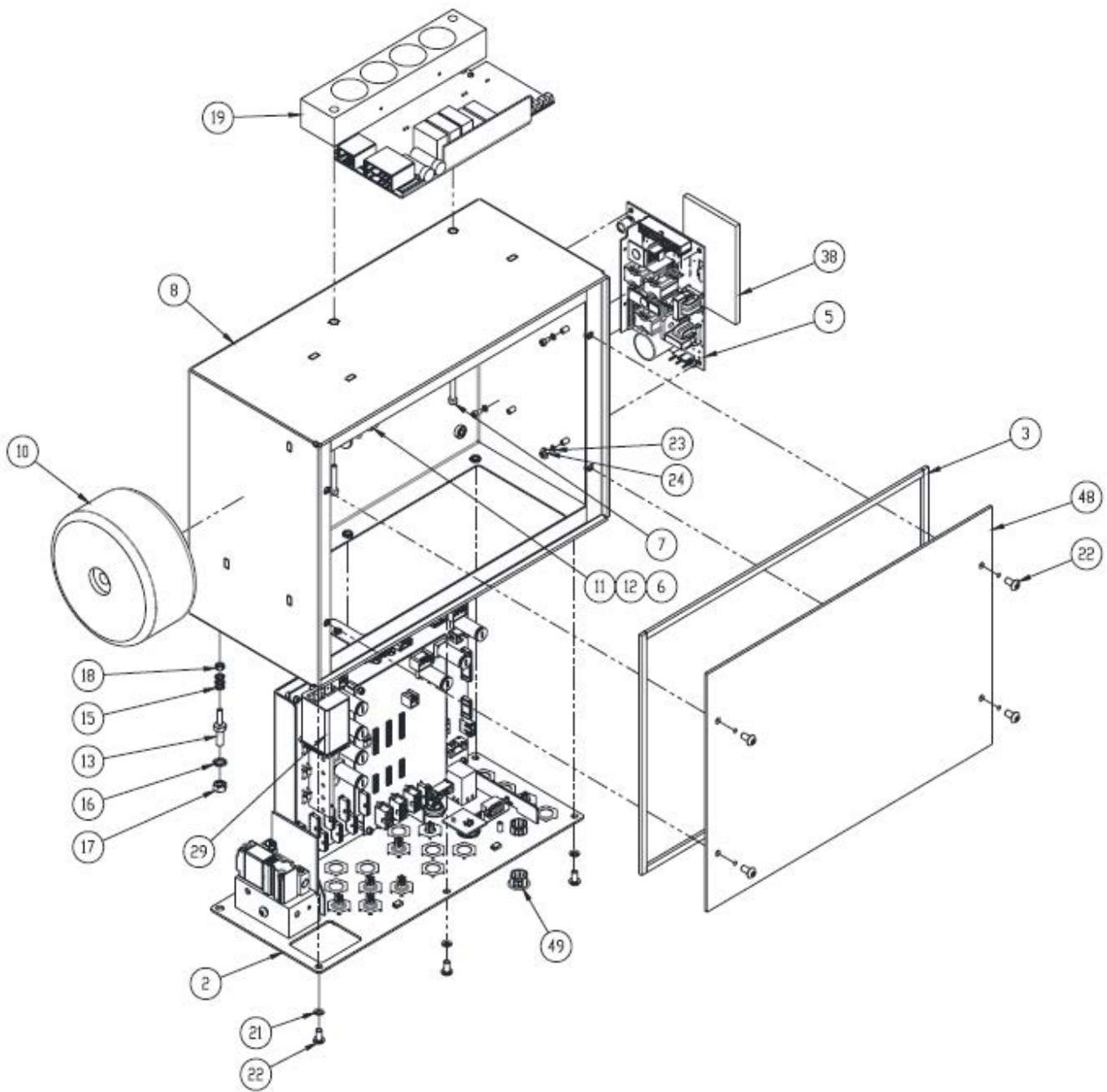

## MCP-8I Unit - Remote Base Assembly (JTS0105) - Continued

Item	Description	Part Number	QTY
2	PCB RACK ASSY	074XX100	1
5	POWER SUPPLY	148XX089	1
6	PLAIN WASHER	784XX097	1
7	SCREW	784XX050	2
8	ENCLOSURE, MCP-8	026XX342	1
9	GASKET	746XX237	47
10	CABLE ASSY, TRANSFORMER P/S	029XX604	1
11	SCREW	884XX069	1
12	WASHER, SPLIT LOCK	784XX663	1
13	GROUNDING STUD	091XX519	1
14	SERIAL LABEL	781XX780	1
15	LOCK WASHER	784XX308	3
16	LOCK WASHER	784XX375	2
17	HEX NUT	798XX301	1
18	HEX NUT	798XX299	1
19	PCB ASSEMBLY; POWER CONTROL	151XX719	1
21	WASHER, SPLIT LOCK	784XX475	5
22	SCREW	784XX374	9
23	WASHER	784XX315	4
24	SCREW	784XX049	4
25	SCREW	784XX656	4
29	POWER ENTRY MODULE	086XX075	1
30	CABLE ASSY	029XX602	2
31	CABLE ASSY	029XX766	2
32	CABLE ASSY	029XX765	1
33	CABLE ASSY, RIBBON	033XX160	1
36	INSTALL KIT, ELEC, MCP8	091XX687	1
37	CABLE ASSY	029XX740	1
38	THERMAL PAD	101XX021	1
39	WASHER	798XX382	2
41	CABLE ASSY, SIGNAL STAND BY	030XX791	1
42	WIRE TERMINAL	075XX079	2
43	WIRE TERMINAL	075XX014	1

*MCP-8I Unit - Remote Base Assembly (JTS0105) - Continued*

<b>Item</b>	<b>Description</b>	<b>Part Number</b>	<b>QTY</b>
44	WIRE	540XX072	6
45	WIRE TERMINAL	075XX245	1
46	WIRE	540XX051	12
48	COVER PLATE, MCP-8 REMOTE	026XX345	1
49	HOLE PLUG	781xx228	1
50	WASHER	884XX424	2
51	ILLUSTRATION DRAWING	BAW3790	1



**MCP-8I Unit - Remote Base Assembly for TIPSEALER (JTS0135)**

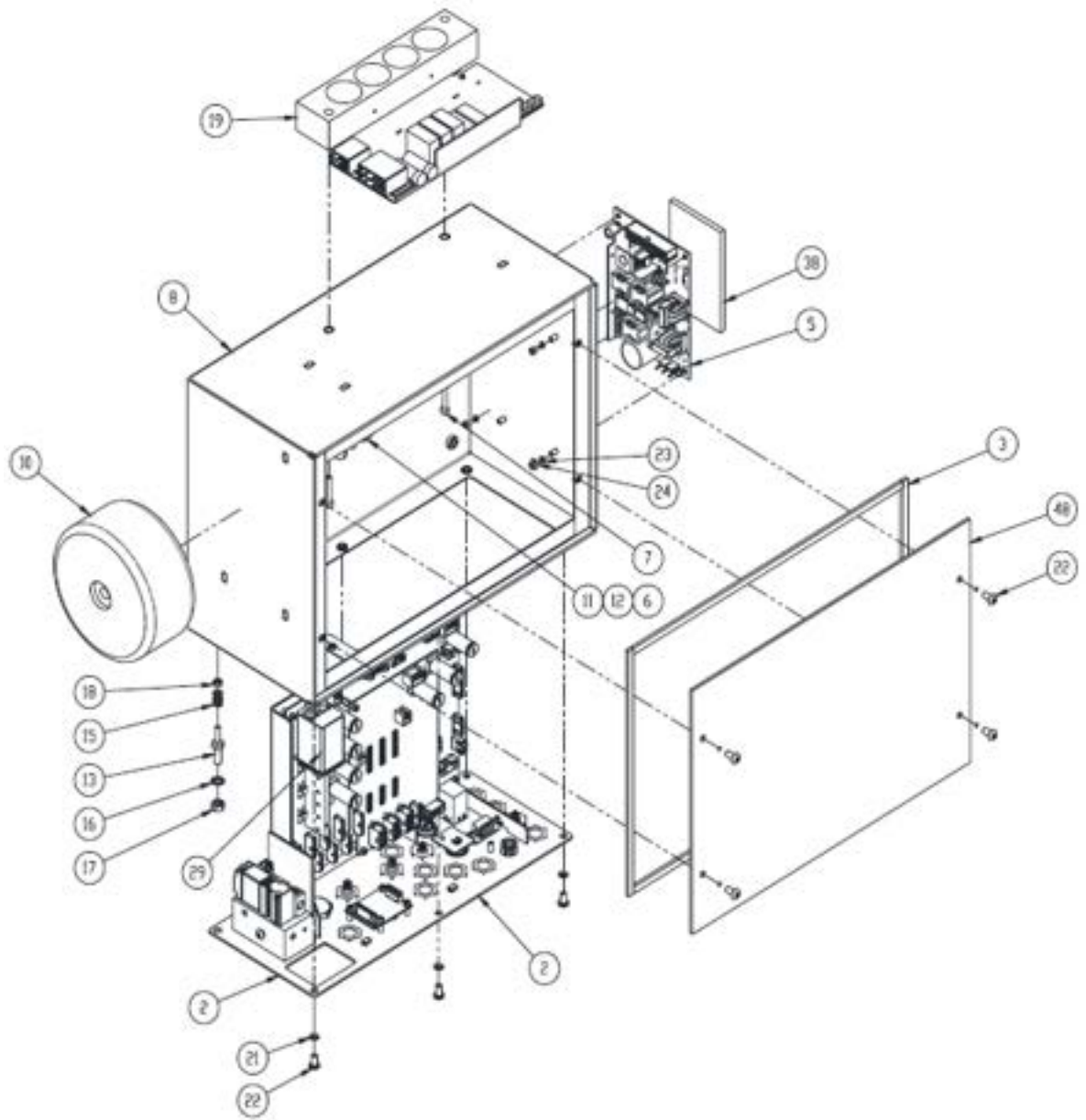

## MCP-8I Unit - Remote Base Assembly for TIPSEALER (JTS0135) - Continued

Item	Description	Part Number	QTY
2	PCB RACK ASSY	JTS0133	1
5	POWER SUPPLY	148XX089	1
6	PLAIN WASHER	784XX097	1
7	SCREW	784XX050	2
8	ENCLOSURE, MCP-8	026XX342	1
9	GASKET	746XX237	47
10	CABLE ASSY, TRANSFORMER	029XX604	1
11	SCREW	884xx069	1
12	WASHER	784XX663	1
13	GROUNDING STUD	091XX519	1
14	SERIAL LABEL	781XX780	1
15	LOCK WASHER	784XX308	3
16	LOCK WASHER	784XX375	2
17	HEX NUT	798XX301	1
18	HEX NUT	798XX299	1
19	PCB ASSEMBLY; POWER CONTROL	151XX719	1
21	WASHER	784XX475	5
22	SCREW	784XX374	9
23	WASHER	784XX315	4
24	SCREW	784XX049	4
25	SCREW	784XX656	4
29	POWER ENTRY MODULE	086XX075	1
30	CABLE ASSY	029XX602	2
31	CABLE ASSY	029XX766	2
32	CABLE ASSY	029XX765	1
33	CABLE ASSY, RIBBON	033XX160	1
36	INSTALL KIT, ELEC, MCP8	091XX687	1
37	CABLE ASSY	029XX740	1
38	THERMAL PAD	101XX021	1
39	WASHER	798XX382	2
41	CABLE ASSY, SIGNAL STAND BY	030XX791	1
42	WIRE TERMINAL	075XX079	2
43	WIRE TERMINAL	075XX014	1

*MCP-8I Unit - Remote Base Assembly for TIPSEALER (JTS0135) - Continued*

<b>Item</b>	<b>Description</b>	<b>Part Number</b>	<b>QTY</b>
44	WIRE	540XX072	6
45	WIRE TERMINAL	075XX245	1
46	WIRE	540XX051	12
48	COVER PLATE, MCP-8 REMOTE	026XX345	1
50	WASHER	884XX424	2
51	ILLUSTRATION DRAWING	BAW3790	1

**Rack Assembly (074XX100)**

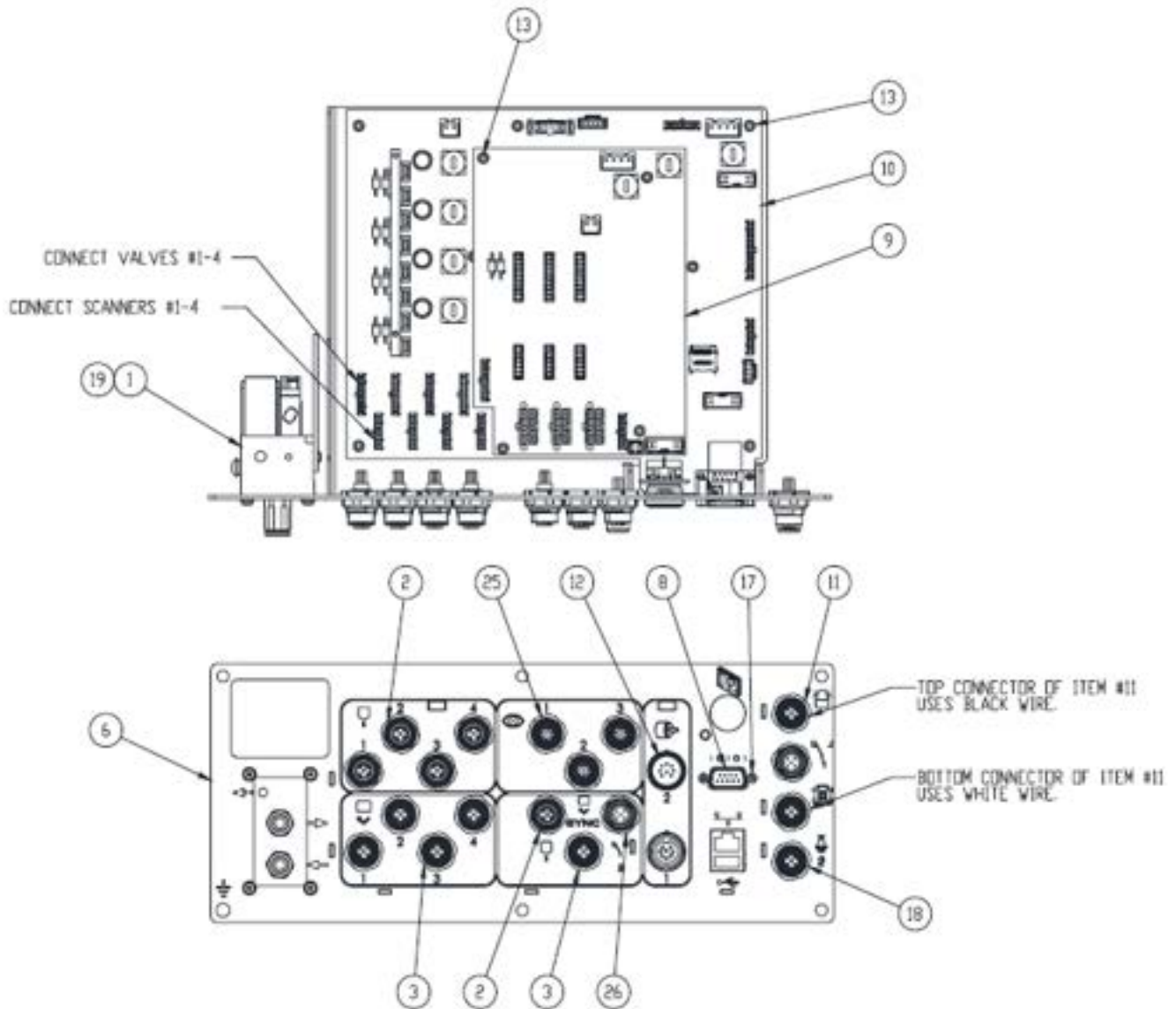

## Rack Assembly (074XX100) - Continued

Item	Description	Part Number	QTY
1	MANIFOLD ASSY, MCP-8 0-10V	753XX455	1
2	CABLE,ASSY,M12,REV,MICROFIT	029XX644	5
3	CABLE,ASSY,M12,STD,MICROFIT	029XX645	5
6	WELDMENT RACK MCP-8I	026XX459	1
8	RIBBON CABLE ASSY,9D/10S,4"	033XX166	1
9	PCB SUBA INSP-CNTRL 3CH MCP-8I	152XX755	1
10	PCB ASSY, MAIN CONT., MCP-8I	152XX819	1
11	CABLE ASSY, M12X3, MCP8	029XX599	1
12	PCB ASSY ENCODER2-CONN MCP-4/8	151XX688	1
13	SHCS SEMS M3 X 6MM	884XX533	12
17	*SCREW,JACK,HEX,4-40,12MM	091XX267	2
18	*CABLE ASSY,5P M12 F TO 5P MCT	029XX397	1
20	MEMORY;MICRO SD, 4GB OR MORE	118XX187	1
21	SOFTWARE, MCP-8, BOOTLOADER	119XX272	1
22	SOFTWARE, MCP-8I, APPLICATION	119XX323	1
23	SOFTWARE, MCP-8I, FPGA	119XX324	1
24	SOFTWARE, MCP-8, FPGA	119XX274	1
25	*CABLE ASSY,8P F M12 STD KEY	029XX809	3
26	CABLE ASSY 5P-M12/5P-MF 4-IN	029XX421	1
27	ILLUSTRATION DRAWING	998IS863	1

Rack Assembly (JTS0133)

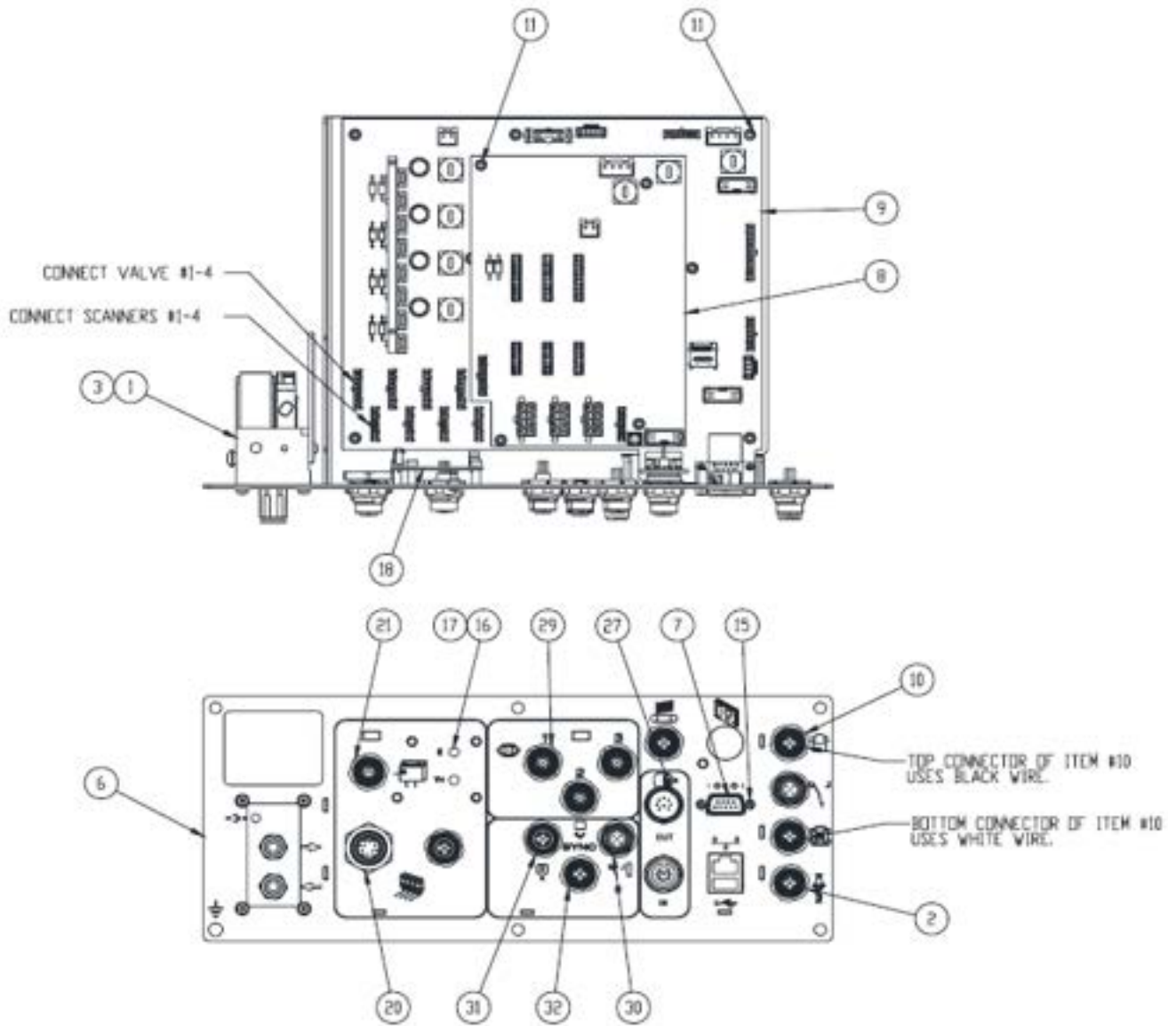

*Rack Assembly (JTS0133) - Continued*

Item	Description	Part Number	QTY
1	MANIFOLD ASSY.	753XX436	1
2	CABLE ASSY.	029XX397	1
3	CABLE ASSY.	029XX657	1
6	PCB RACK ASSY	SMT8001	1
7	RIBBON CABLE ASSY.	033XX166	1
8	PCB SUBA INSP-CONT.	152XX755	1
9	PCB ASSY, MAIN CONT.	JTS0111	1
10	CABLE ASSY.	029XX599	1
11	SCREW	884XX533	20
15	SCREW	091XX267	2
16	LENS	105XX323	2
17	RETAINING RING	105XX322	2
18	PCB ASSY SLND-DRVR TIP-SEALER	152XX674	1
20	CABLE ASSY.	029XX639	1
21	MANIFOLD CABLE ASSY.	029XX618	1
22	MEMORY, MICRO SD	118XX187	1
23	SOFTWARE, MCP-8, BOOTLOADER	119XX272	1
25	SOFTWARE, MCP-8I, APPLICATION	JTS0106	1
26	SOFTWARE, MCP-8, FPGA	119XX274	1

---

***Recommended Replacement Parts***

---

**On PCB Assy., Power Control (151xx719)**

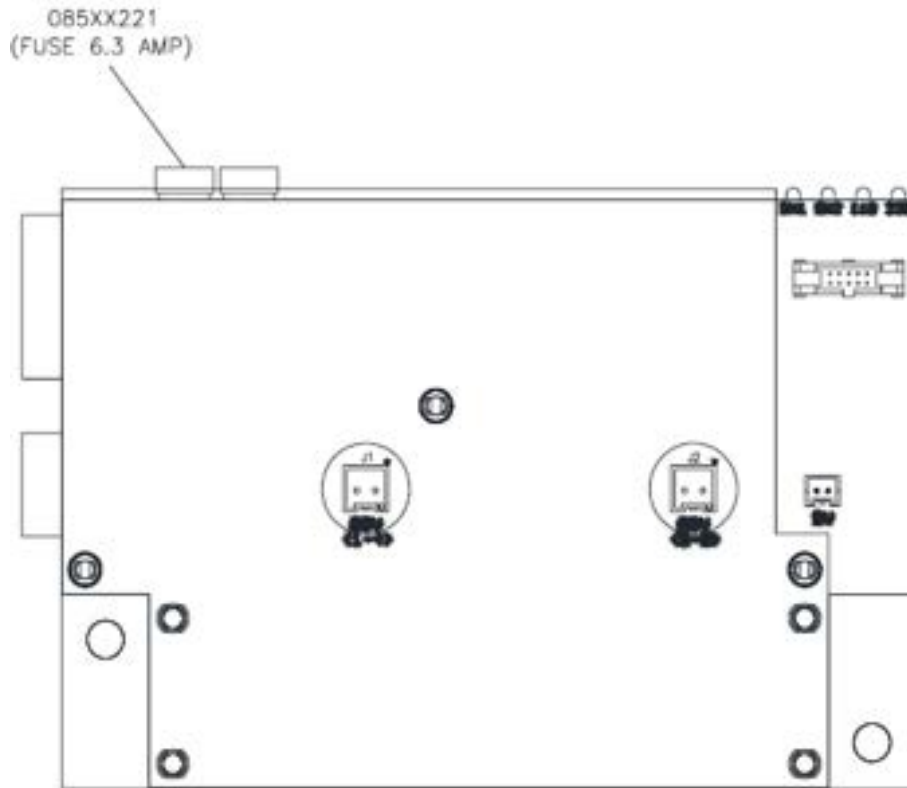



# MCP-8I Unit - Remote Display Touchscreen (JTS0137)

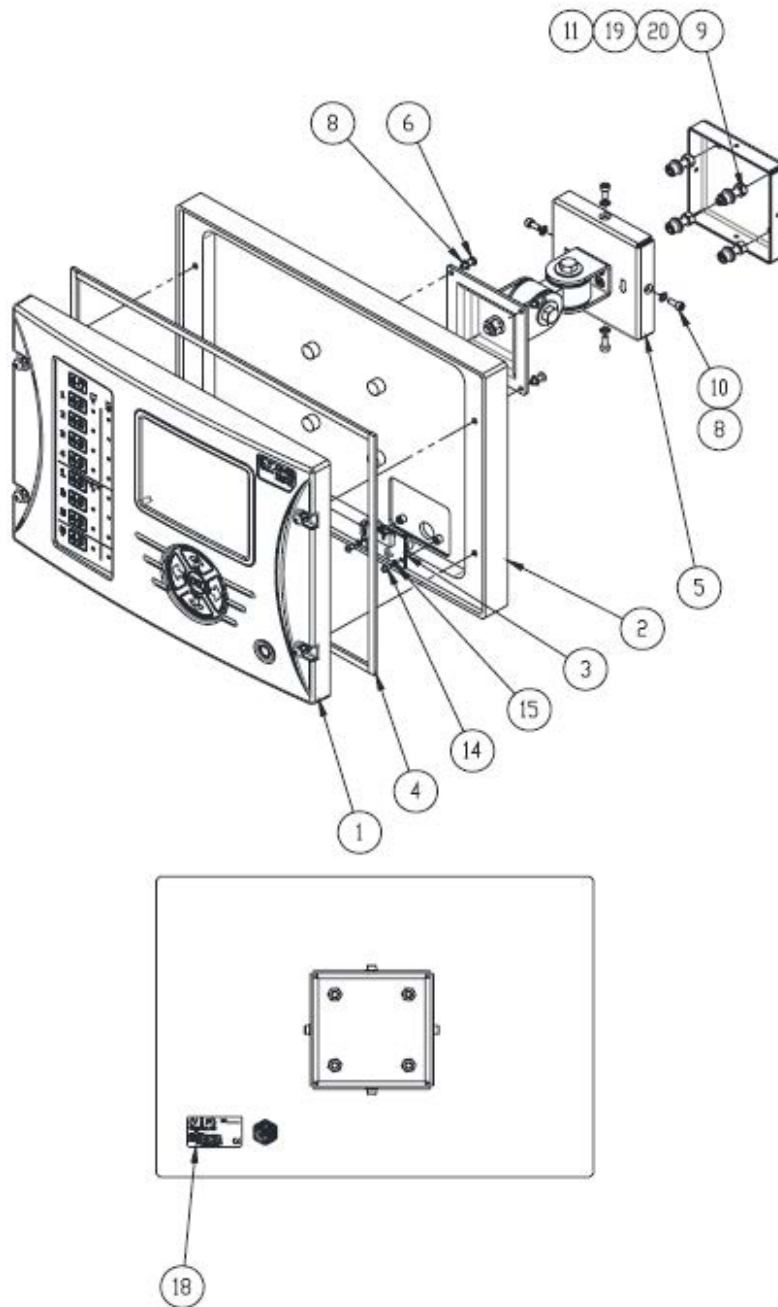

*MCP-8I Unit - Remote Display Touchscreen (JTS0137) - Continued*

<b>Item</b>	<b>Description</b>	<b>Part Number</b>	<b>QTY</b>
1	COVER ASSY, MCP-8, INSPECTION	JTS0100	1
2	BACK PLATE MCP-8 REMOTE	026XX344	1
3	PCB ASSY CONN REM-DISP MCP-8	151XX729	1
4	GASKET	746XX237	47
5	MOUNT,MNTR,TLT/SWVL & ROTATE	582XX799	1
6	SCREW	784XX575	4
8	WASHER-LOCK,EXTERNAL TOOTH	784XX973	8
9	SCREW	784XX426	4
10	SCREW	784XX423	4
11	WASHER	784XX600	4
12	CABLE ASSY	029XX740	1
13	CABLE ASSY, SIGNAL STAND-BY	030XX791	1
14	SCREW	784XX541	2
15	WASHER-LOCK,SPLIT	784XX976	2
16	FOAM SET, MCP-8 REMOTE DISPLAY	730XX115	1
17	BOX #22	730XX039	1
18	LABEL STOCK, SILVER	781XX780	1
19	NUT	793XX491	4
20	FLAT WASHER	784XX183	4
21	SCREW	798XX069	4
22	ILLUSTRATION DRAWING MCP-8	999XA138-04	1

**Cover Assembly (026XX458)**

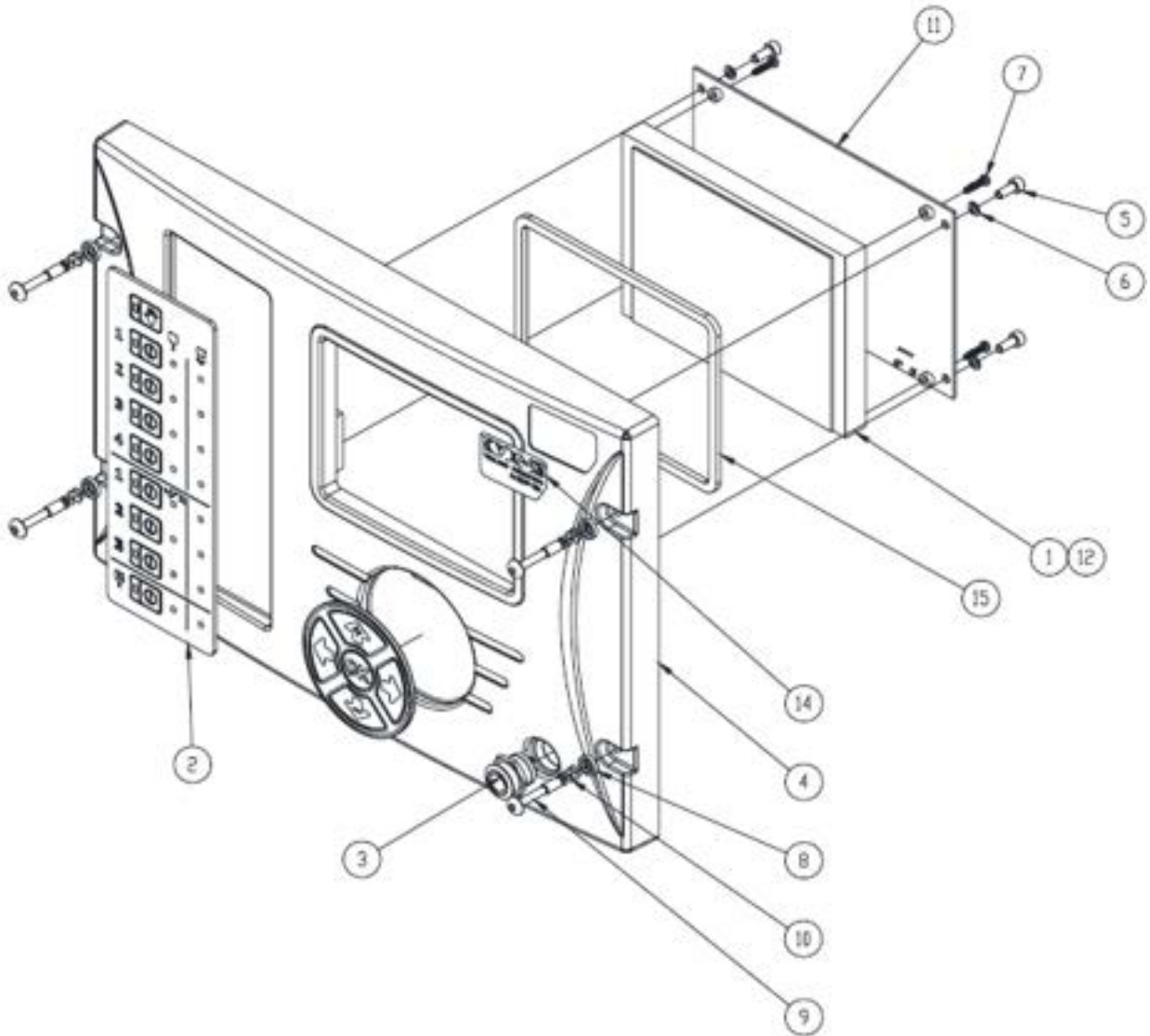

*Cover Assembly (026XX458) - Continued*

Item	Description	Part Number	QTY
1	DISPLAY; COLOR TFT, 5.7"	137XX023	1
3	CABLE ASSY., PB SWITCH, MCP8	029XX878	1
4	COVER - FRONT; MCP-8 CONTROL	026XX340	1
5	SHCS M4 X 10 STAINLESS	784XX423	4
6	SLW M4 ZINC	798XX382	4
7	SCREW SELF TAPPING M3 X 12MM	884XX317	4
8	SCREW BEZEL	783XX223	4
9	SCREW CAPTIVE M5; MCP-8	884XX318	4
10	TAPERED COMPRESSION SPRING	783XX222	4
11	PCB SUBA LCD/KYPD-CNTRL MCP-8	152XX716	1
12	*CABLE ASSY FFC 33P 0.5MM 50MM	033XX181	1
13	NUT, LOCK, M3 X .5, SS	884XX009	2
14	LABEL MCP-8I FRONT COVER	782XX722	1
15	GASKET MCP-8 TOUCHSCREEN	746XX255	1
16	KEYPAD VALVE & SENSOR MCP-8I	782XX738	1
17	KEYPAD ARROW, MCP-8	782XX737	1

## Recommended Replacement Parts

*(On PCB Assembly, 151xx697)*

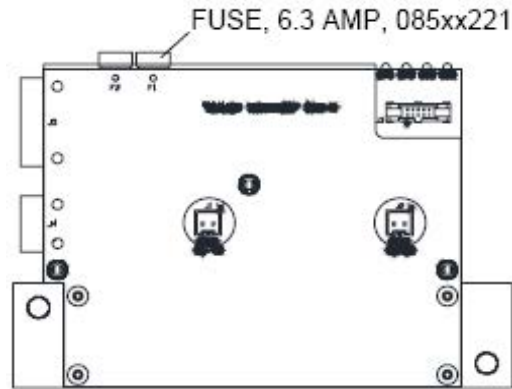

## Standard Mounting System

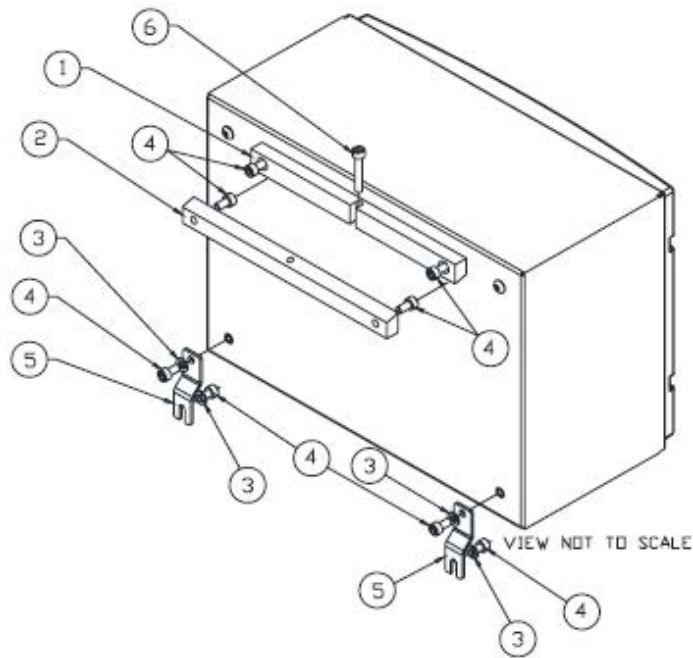

Item	Description	Part Number	QTY
1	Mounting Rail, to enclosure	583xx413	1
2	Mounting Rail, to wall/panel	583xx412	1
3	Lock washer, M6	784xx600	4
4	SHCS, M6 x 12	798xx069	8
5	Mounting Foot	583xx414	2
6	SHCS, M6 x 35	884xx105	1

# Wiring Diagrams

## *FlexoSEAL with MCP-8I, Stand-alone Standard*

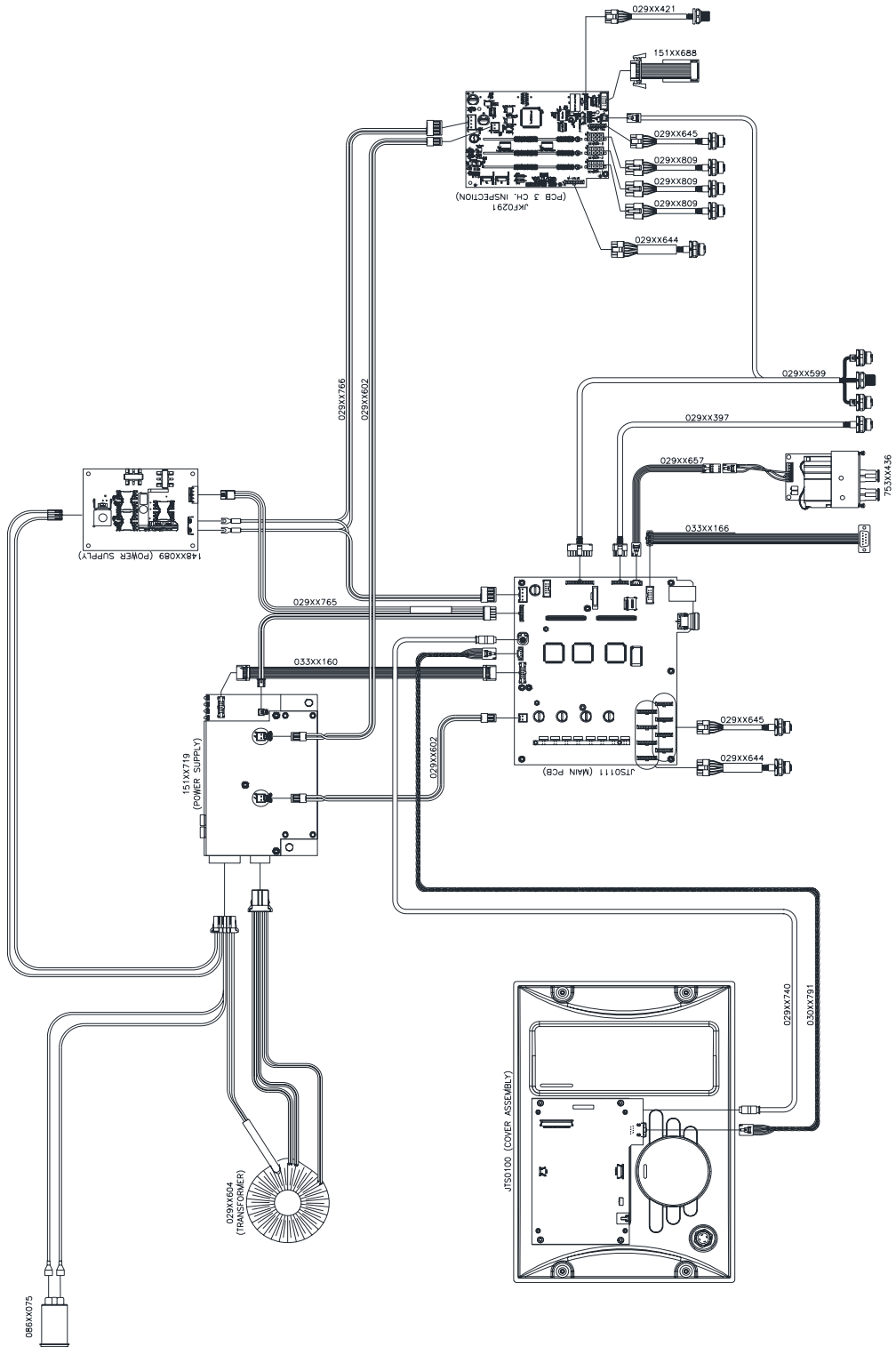

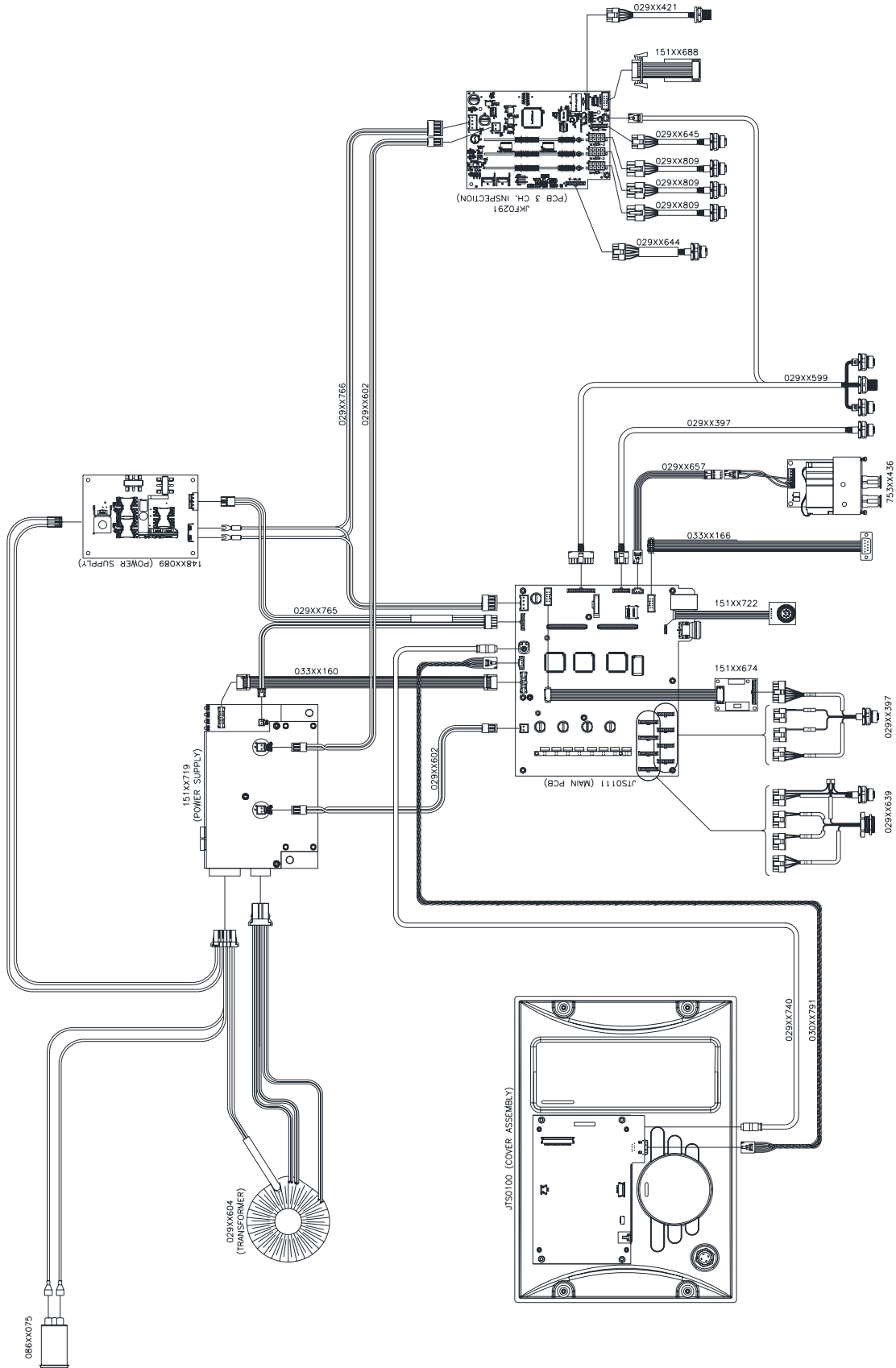

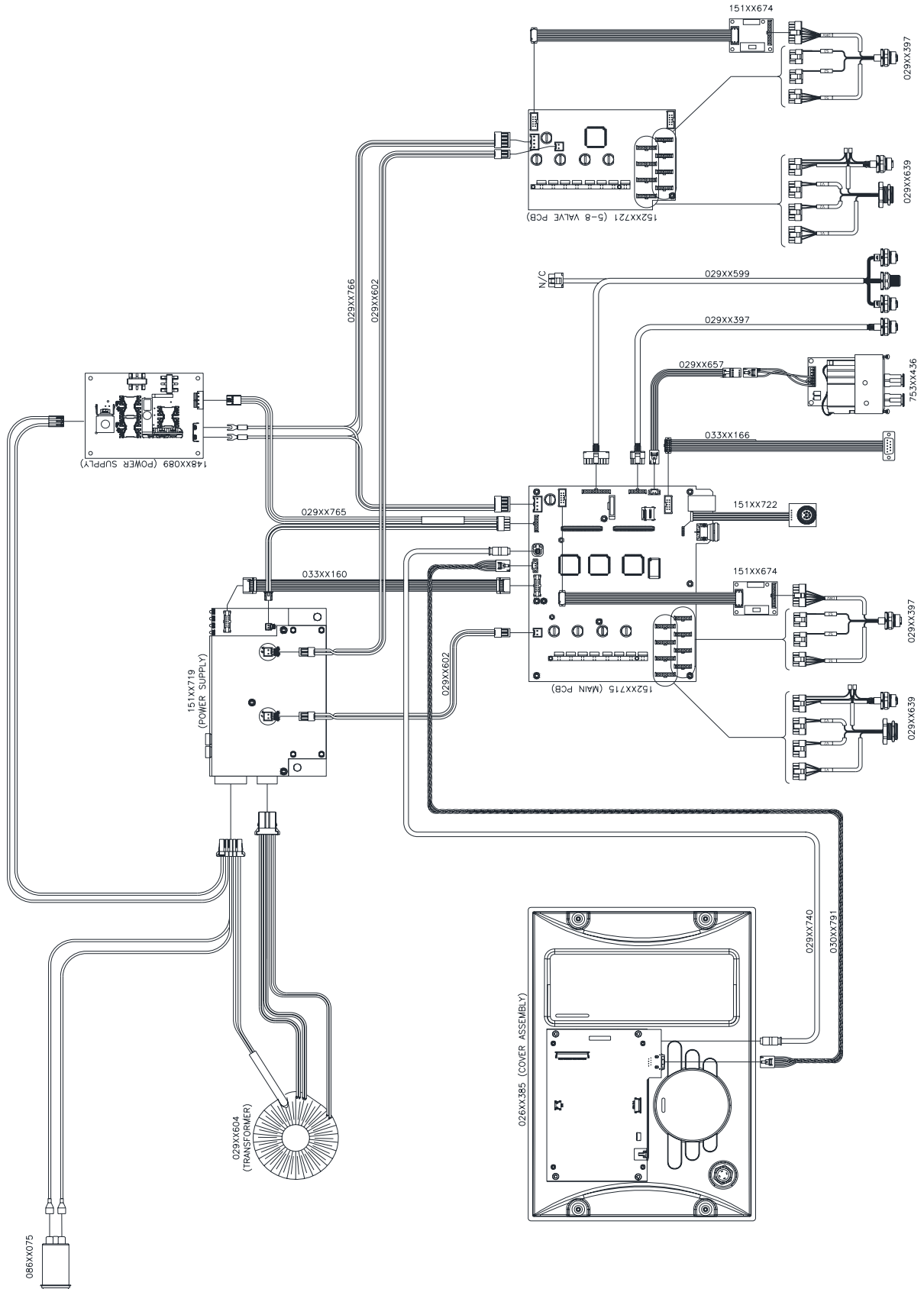



---

## Section 9 - Warranty

---

### Warranty Information

---

Valco Cincinnati, Inc. warrants its equipment worldwide against defects in material and workmanship as outlined in this section.

Liability of the company is limited to repair of the product, or replacement of any part shown to be defective, and does not extend to defects caused by accidents, misuse, abuse, neglect, tampering or deterioration by corrosion. This warranty does not cover those items determined by Valco Cincinnati, Inc. to be normal wear items such as seals, O-rings, diaphragms, springs, etc.

Reconditioned equipment, unless specified otherwise at the time of purchase, will be warranted as described above for a period of ninety (90) days from the date of shipment by Valco Cincinnati.

Components purchased by Valco Cincinnati, Inc. from others for inclusion in its products are warranted only to the extent of the original manufacturer's warranty. In no event shall Valco Cincinnati, Inc. be liable for indirect or consequential damages arising out of the use of Valco Cincinnati products.

This warranty is conditioned upon the prepaid return of the equipment claimed to be defective to Valco Cincinnati, Inc. for examination and verification. If claimed defect is verified, repairs or replacements will be made F.O.B. Cincinnati, Ohio, U.S.A. or ex-works Telford, U.K. If the inspection of the equipment does not disclose any defect of workmanship or material, any necessary repairs will be made at a reasonable charge and return transportation will be charged.

This is the only authorized Valco Cincinnati, Inc. warranty and is in lieu of all other expressed or implied warranties, representations or any other obligations on the part of Valco Cincinnati, Inc.

---

#### ***Cold Glue Equipment and Electronic Controls***

---

The warranty for cold glue equipment and electronic controls for a period of one (1) year from the date of shipment by Valco Cincinnati, Inc.

---

#### ***Hot Melt Units, Hoses, Valves, Guns, and Related Equipment***

---

All hot melt components except cast-in heating elements are warranted for a period of six (6) months from the date of shipment by Valco Cincinnati. Cast-in heaters carry an additional, pro-rated warranty not to exceed three (3) years from the date of shipment by ValcoMelton, a Valco Cincinnati, Inc. company.



---

## Section 10 - Service

---

If a problem with your system persists, contact a ValcoMelton Technical Support representative. If your need is urgent, we encourage you to contact our corporate office in Cincinnati, Ohio, U.S.A. at (513) 874-6550. If the problem cannot be resolved, Valco Cincinnati, Inc. will promptly arrange to have a technical representative visit your facility. Any charges for a service call will be quoted at that time. Any part that fails during the warranty period shall be returned prepaid to Valco Cincinnati, Inc. by the customer for disposition.

 Upon request, ValcoMelton personnel are available to repair or replace such parts at the customer's facility. Charges for this service include travel time and expenses.

If an equipment problem is the result of customer abuse, improper installation or operation, all travel time, labor, parts, and expenses will be charged to the customer.

If the responsibility for a problem cannot be absolutely determined, the customer will be charged for travel time and expenses only. No charge will be made for parts and labor.



---

## Appendix A - Job Charts

---

Use the following table to record saved jobs for quick reference, and to prevent duplication/erasure of important job information. The table may be copied for use.

Job Number	Job Name	Description